

REVISIONS			
REV.	DESCRIPTION	DATE	APPROVED
A	ORIGINAL RELEASE	4-06-16	DM
A1	ADDED HOUSING VERSION	10-20-16	DNH
A2			DNH

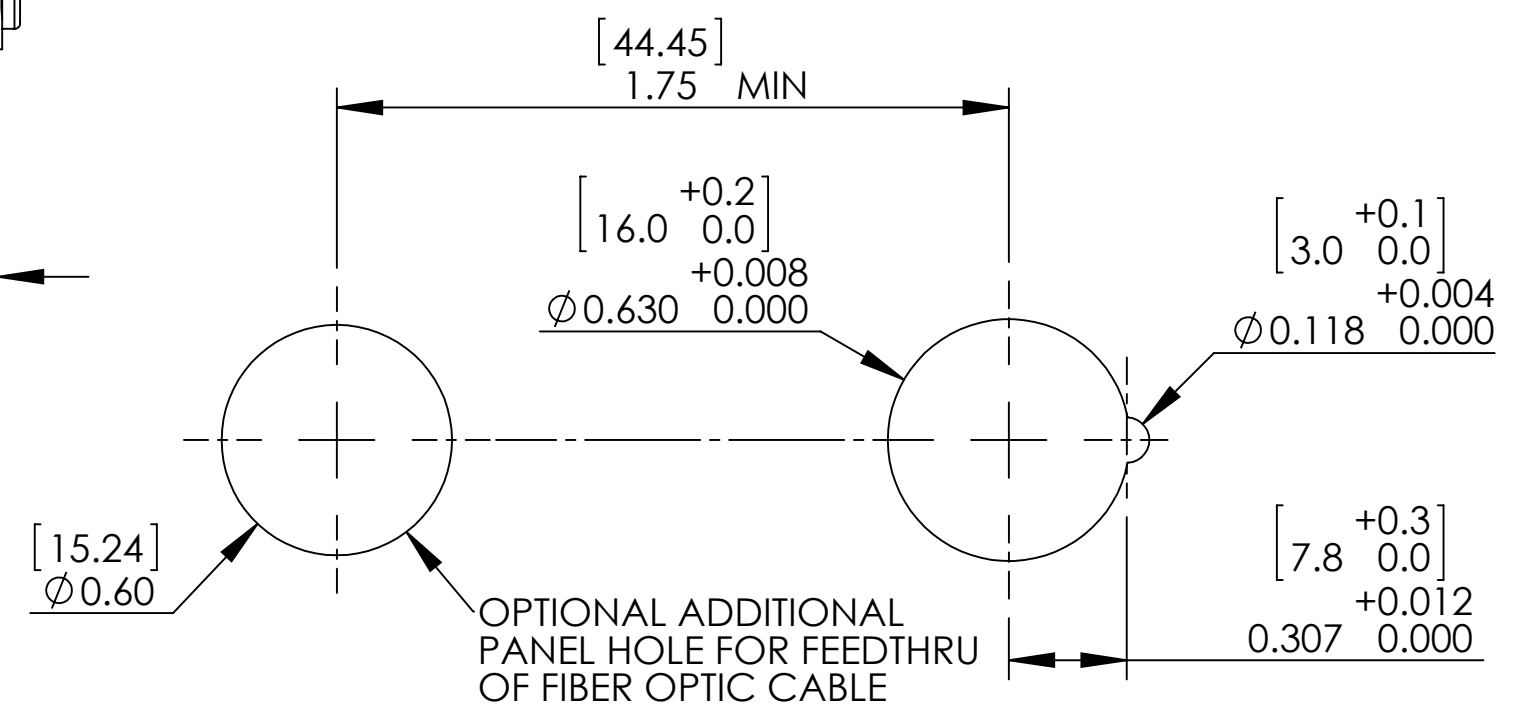
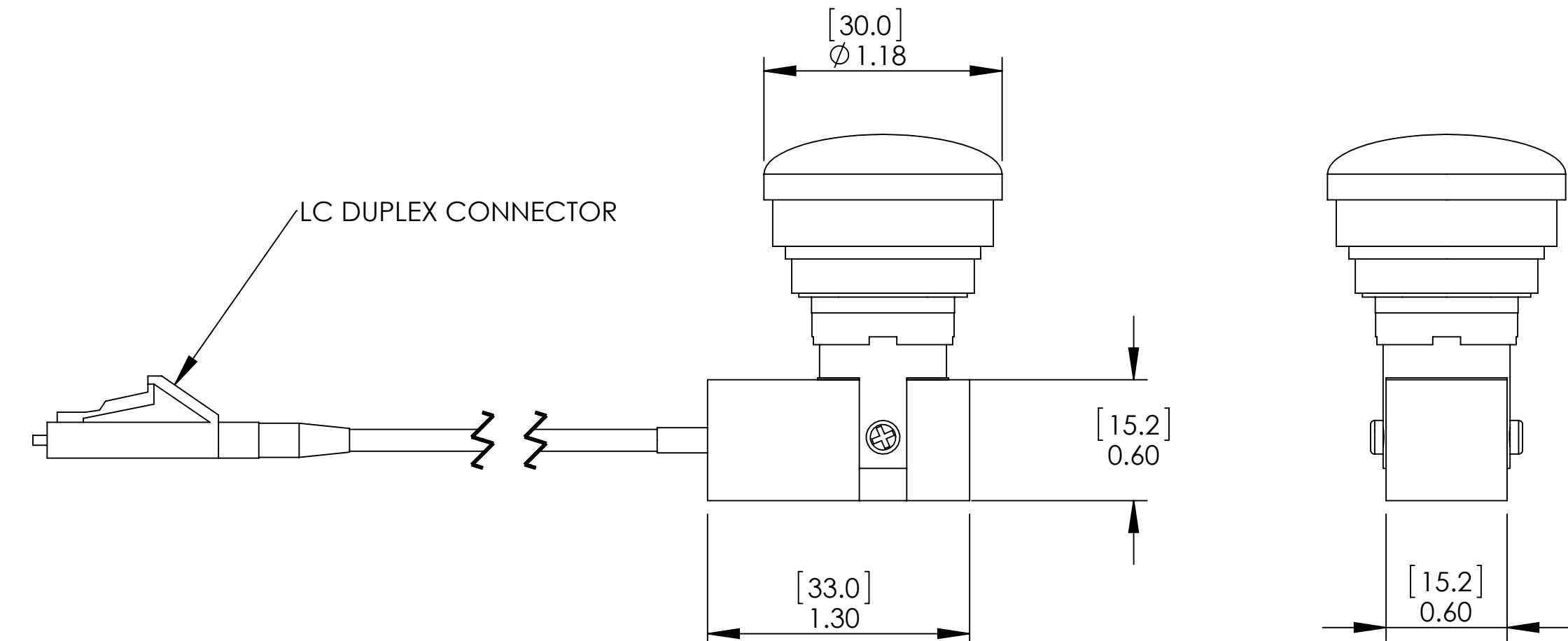
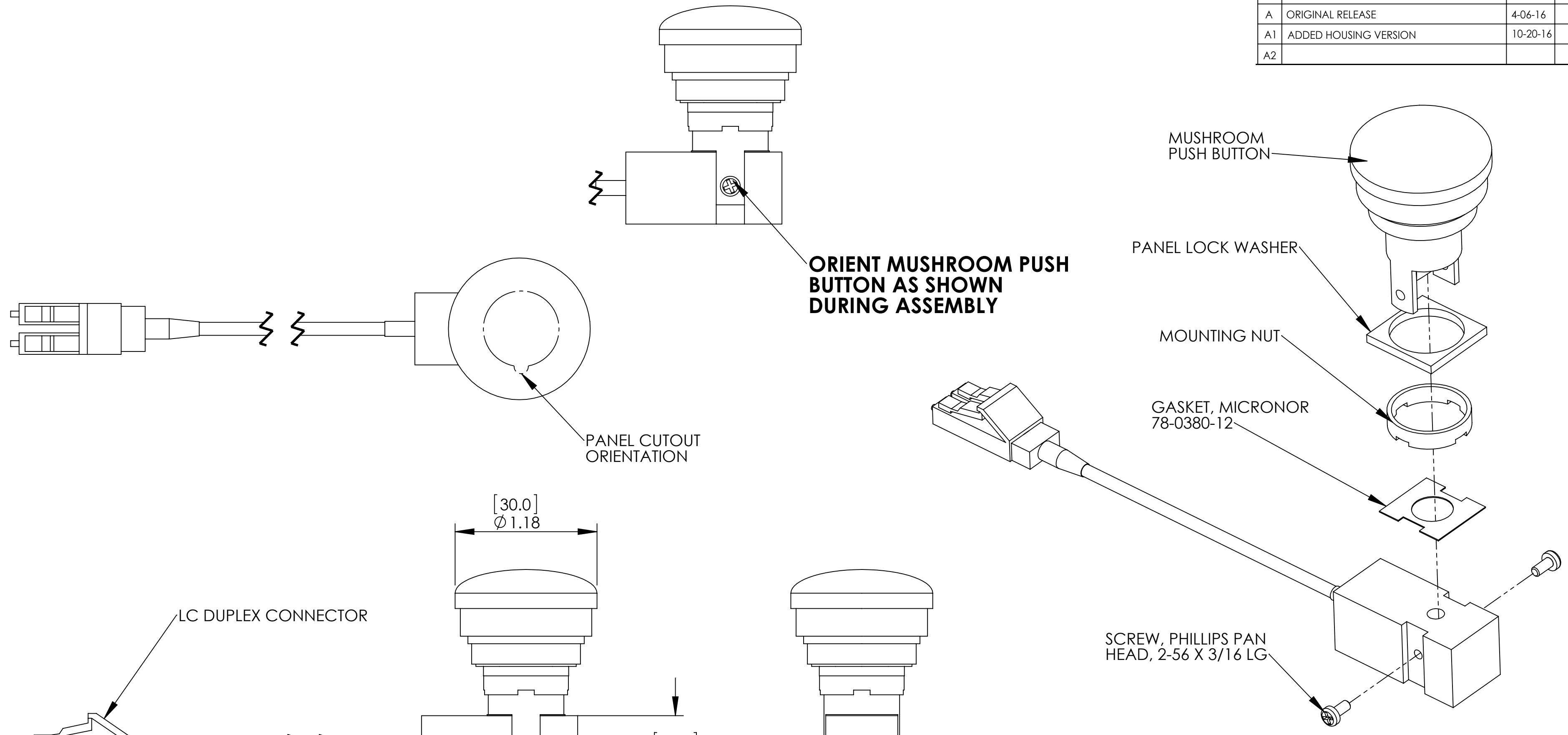

**PART NUMBER ORDERING CODE**  
 MR381 - 2 S - 03

CABLE LENGTH IN METERS  
 1R5 = 1.5 METERS  
 03 = 3 METERS (STANDARD)  
 05 = 5 METERS  
 CONSULT FACTORY FOR OTHER LENGTHS

S = Ø30mm BUTTON  
 M = Ø40mm BUTTON

2 = WITH 62.5/125 OM1 FIBER  
 5 = WITH SINGLE MODE OS1 FIBER  
 5 = WITH 50/125 OM2 FIBER

2 WARNING: KEEP CONNECTOR COVERS IN PLACE DURING STORAGE, TO PROTECT FIBER OPTIC INTERFACES.

1 WARNING: AVOID SHARP BENDS AND CABLE PINCHING. KEEP BEND RADIUS GREATER THAN 0.5 INCH [13MM].

NOTES: UNLESS OTHERWISE SPECIFIED

UNLESS OTHERWISE SPECIFIED:		NAME	DATE	MICRONOR INC.	
DIMENSIONS ARE IN INCHES		DRAWN	R BOYER	8-15-13	NEWBURY PARK, CA (805) 499-0114
TOLERANCES:		CHECKED			TITLE:
ANGULAR: ± 5°		ENG APPR.			FIBER OPTIC
TWO PLACE DECIMAL ±.02		MFG APPR.			E-ACTUATOR SWITCH
THREE PLACE DECIMAL ±.005		Q.A.			SIZE DWG. NO.
FOUR PLACE DECIMAL ±.0010		COMMENTS:			C MR381
INTERPRET GEOMETRIC TOLERANCING PER:					REV
MATERIAL					A2
FINISH					SCALE: 1.5:1 WEIGHT:
DO NOT SCALE DRAWING					SHEET 1 OF 2

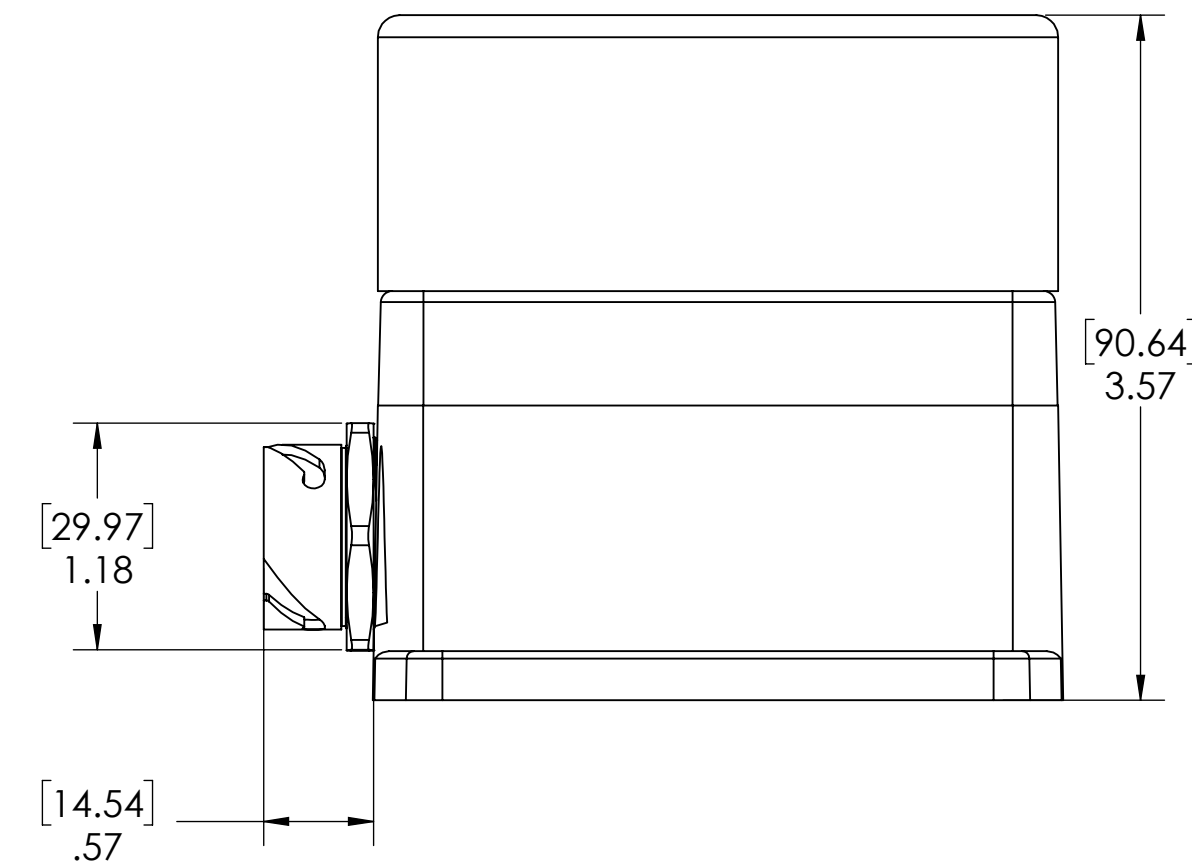
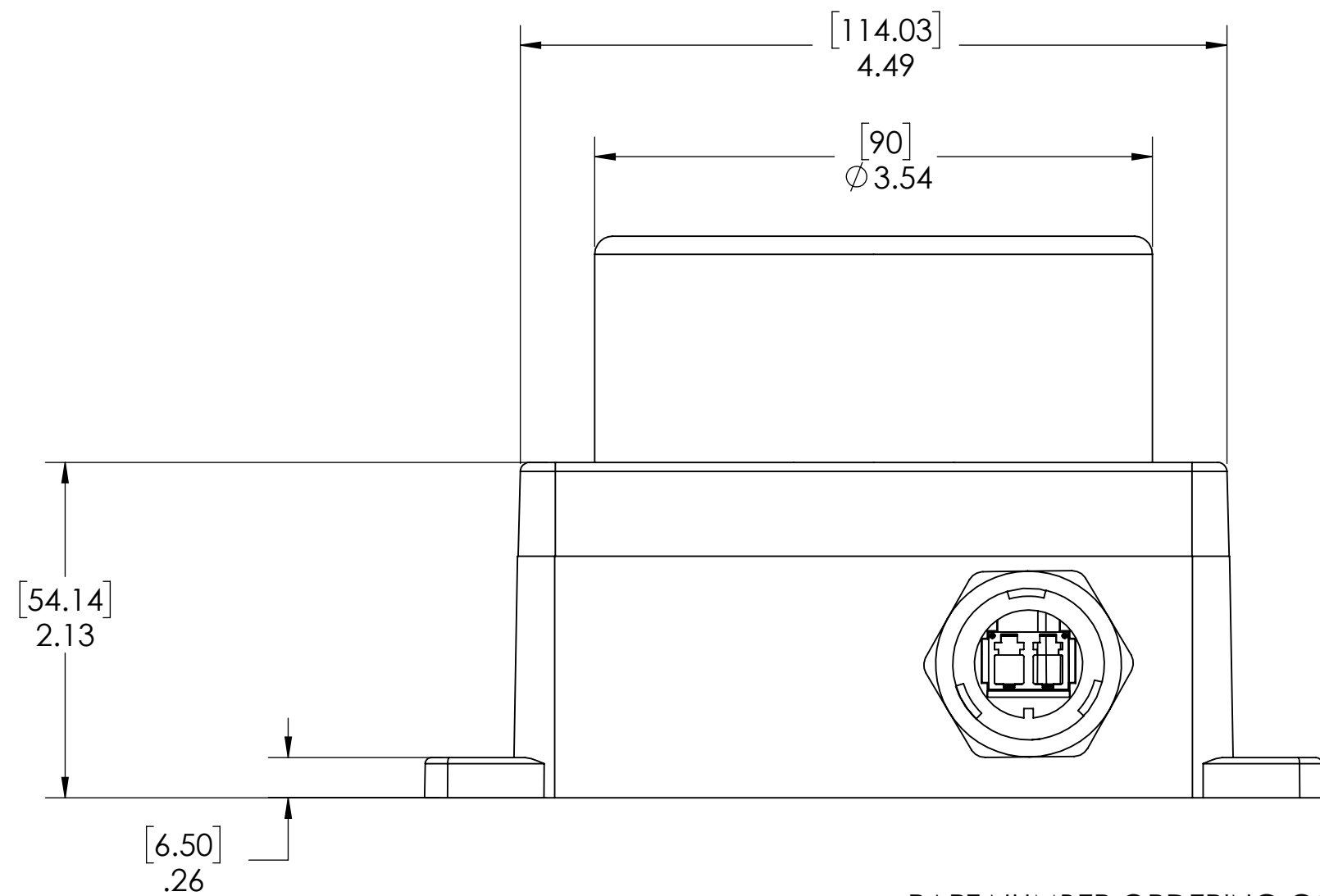
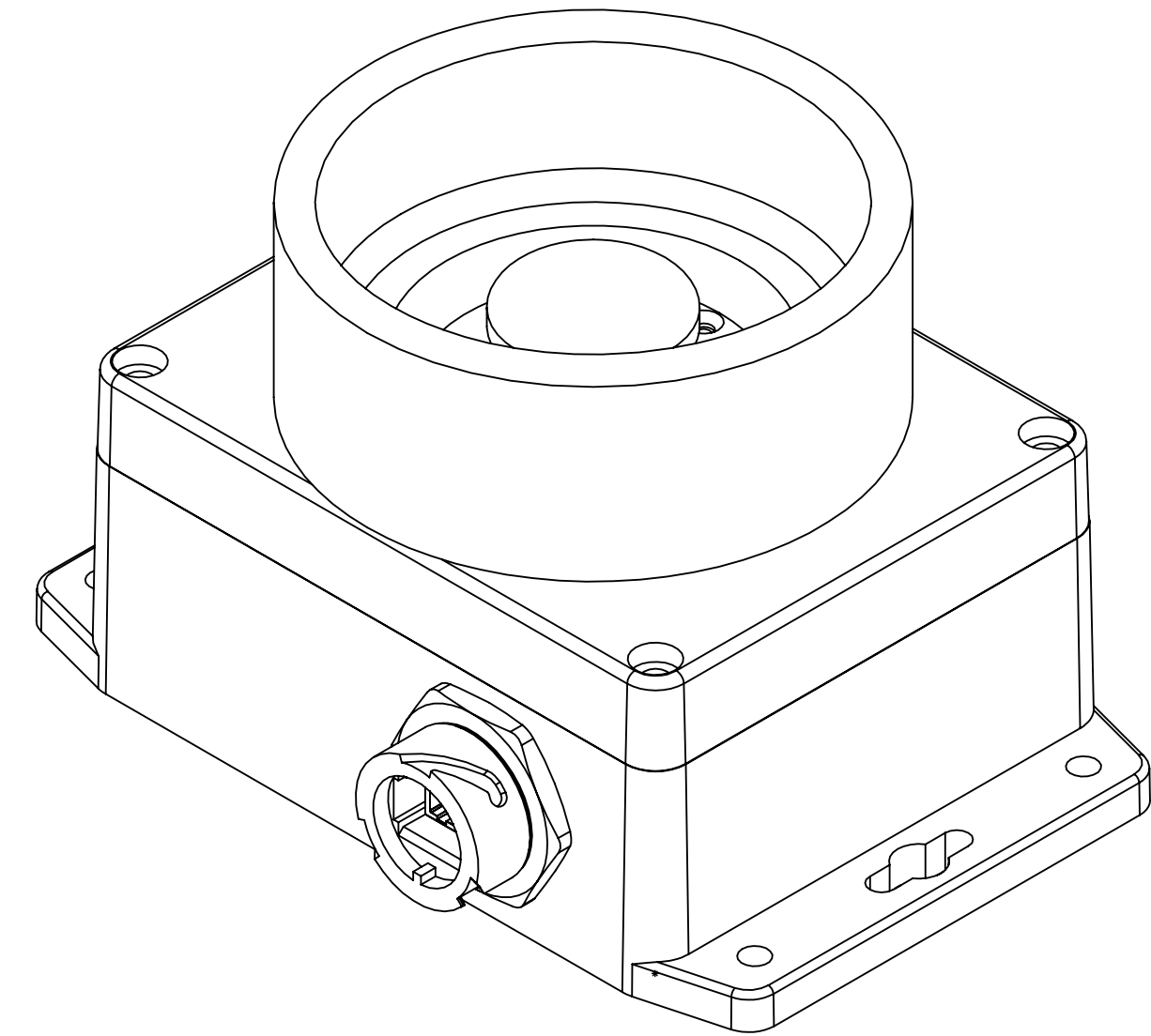
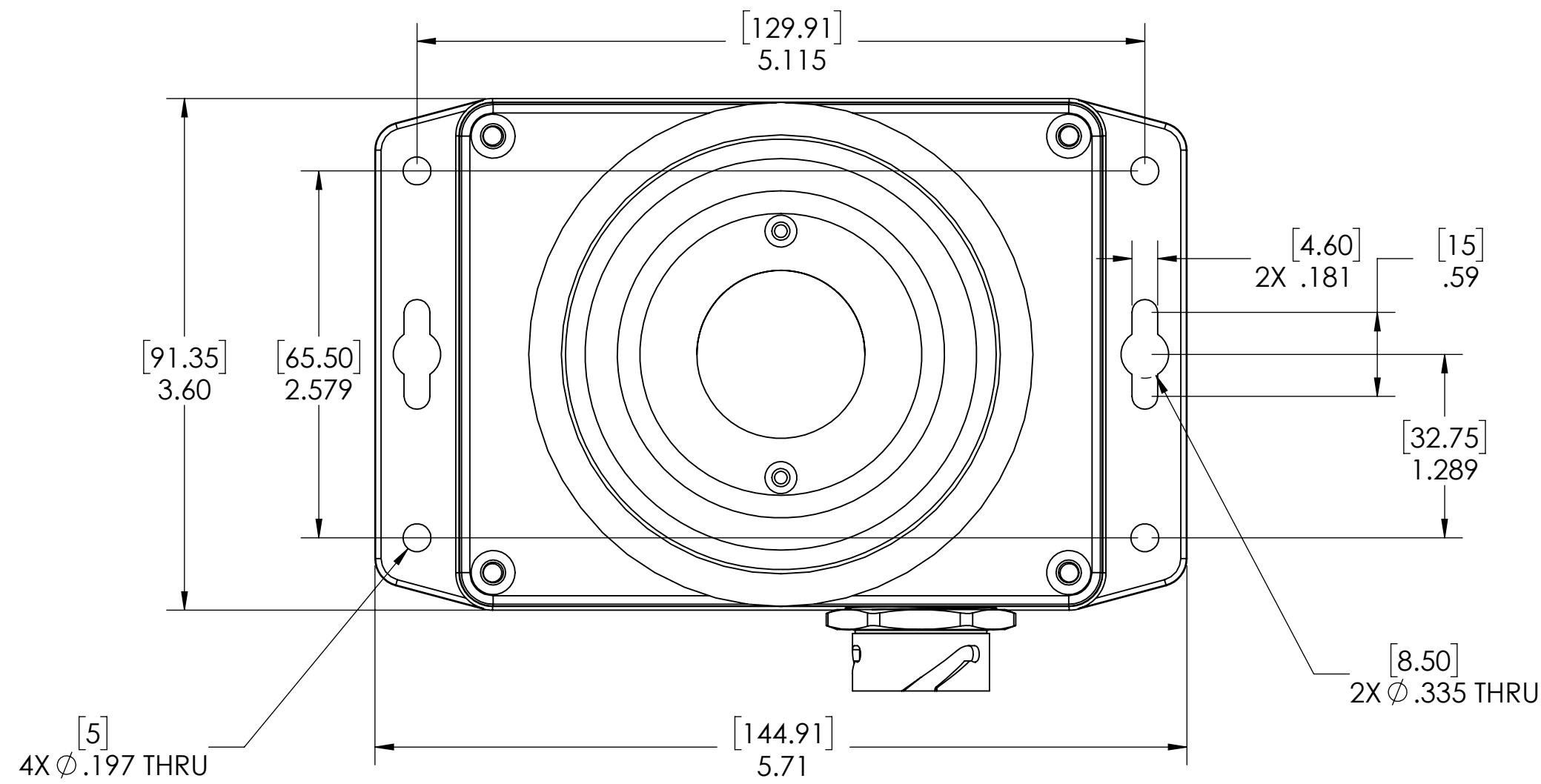

PART NUMBER ORDERING CODE

MR381- 2 S - D00

S = Ø30MM BUTTON  
M=Ø40MM BUTTON

2=WITH 62.5/125 OM1-FIBER  
3=WITH SINGLE MODE OS1 FIBER  
5=WITH 50/125 OM-2 FIBER

1 WARNING: KEEP CONNECTOR COVERS IN PLACE DURING STORAGE TO PROTECT FIBER OPTIC INTERFACES

NOTES: UNLESS OTHERWISE SPECIFIED

**PROPRIETARY AND CONFIDENTIAL**  
THE INFORMATION CONTAINED IN THIS DRAWING IS THE SOLE PROPERTY OF MICRONOR INC. ANY REPRODUCTION IN PART OR AS A WHOLE WITHOUT THE WRITTEN PERMISSION OF MICRONOR INC. IS PROHIBITED.

		UNLESS OTHERWISE SPECIFIED:		NAME	DATE	MICRONOR INC. CAMARILLO, CA (805) 389-6600		
		DIMENSIONS ARE IN INCHES		DRAWN	A DU	6/10/16	TITLE:	
		TOLERANCES:		CHECKED			<b>E-ACTUATOR, ENCLOSURE</b>	
		FRACTIONAL ±		ENG APPR.				SIZE DWG. NO.
		ANGULAR: MACH ± BEND ±		MFG APPR.				<b>C</b> <b>MR381</b>
		TWO PLACE DECIMAL ±.01		Q.A.			REV	
		THREE PLACE DECIMAL ±.004		COMMENTS:			<b>A2</b>	
		INTERPRET GEOMETRIC TOLERANCING PER:						SCALE: 1:1 WEIGHT:
		MATERIAL						SHEET 2 OF 2
		SEE NOTES						
		FINISH						
		SEE NOTES						
NEXT ASSY	USED ON	APPLICATION						
		DO NOT SCALE DRAWING						