

6 5 4 3 2 1

SB30 SMART BRACKET STRAIN GAUGE FORCE SENSOR

PATENT PENDING

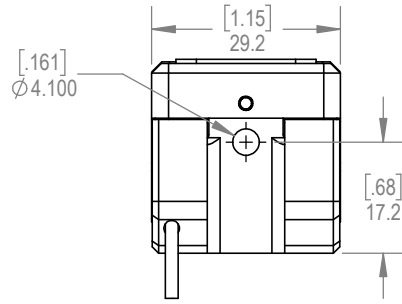
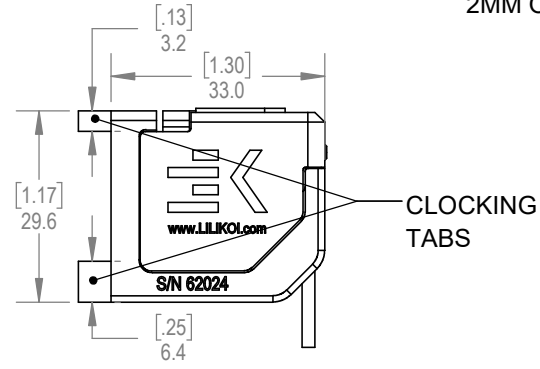
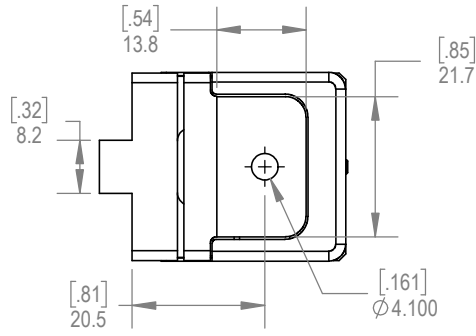
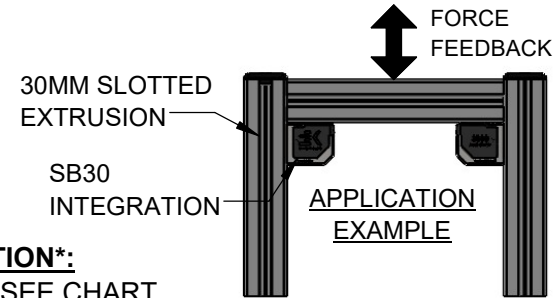
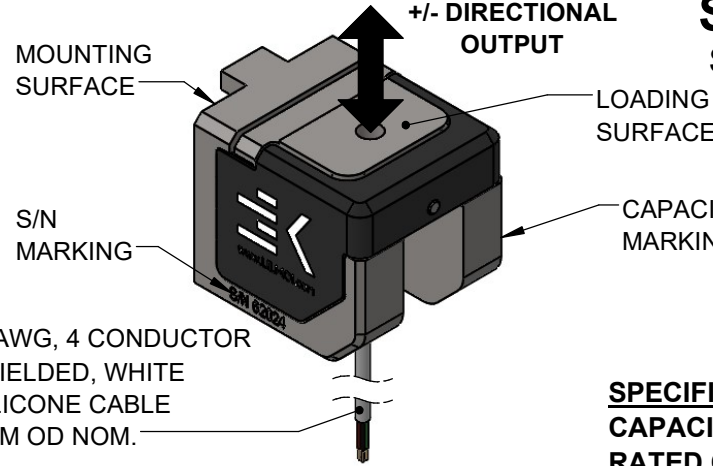

32AWG, 4 CONDUCTOR
SHIELDED, WHITE
SILICONE CABLE
2MM OD NOM.

SPECIFICATION*:
CAPACITY: SEE CHART
RATED OUTPUT: SEE CHART
NON-LINEARITY: 0.1% R.O.
DEFLECTION: 0.25 [0.009]
SAFE OVERLOAD: 400%
BRIDGE RESISTANCE: 1000 Ohm
OPERATING TEMP: -51-71°C [-60-160°F]
TEMP SHIFT ZERO: 0.01% R.O./degC
SENSOR BODY: STAINLESS STEEL
CABLE LENGTH: 2m [6.5ft]
CABLE TERMINATION: PIGTAIL

WIRING CODE

+Excitation	-Excitation	+Signal	-Signal
RED	BLACK	GREEN	WHITE

ITEM #	CAP (KG [LB])	R.O. [mV/V]
LLK-0002	11.3 [25]	1.25
LLK-0003	22.7 [50]	2.5

*CONTACT FACTORY FOR CUSTOM CAPACITY & SPECIAL CONFIGURATIONS: INFO@LILIKOI.COM

ALL DIMENSIONS ARE IN MILLIMETERS, [DUAL DIMENSIONS] ARE IN INCHES/IMPERIAL UNITS. DRAWING INTERPRETATION PER ASME-Y14.5. PATENT PENDING TECHNOLOGY BY LILIKOI innovation LLC. DO NOT REVERSE ENGINEER.

TOLERANCE BLOCK
.X ± .250
.XX ± .125
.XXX ± .050
.XXXX ± .025

ANGLE CHAMFER
± .5° ± 5°
3RD ANGLE PROJ.

DRAWN BY: BL
DATE: 4/27/24
APPROVED BY: MJ
DATE: 5/2/24

TITLE: SB30 SMART BRACKET SPEC
DWG NO.: LP1002
ITEM NO.: SEE CHART

REVISION: REV 0
MODEL NO.: SB30

LILIKOI innovation LLC
2108 N ST STE N, SACRAMENTO, CA 95816, USA



6 5 4 3 2 1