

Commercially Available Fiber Optic Sensors for Medical, Industrial and Aerospace Applications

Seminar Outline

- Market Trends driving need for sensors of all types
- Fiber Optic Sensors solve intrinsic needs, How Fiber Optics work
- How (Some) Fiber Optic Sensors Work (Position, Microswitch, E-Stop, Acceleration, Temperature, and FBGs)
- Case Study #1: Medical RF Radiotherapy and MRI (GaAs Temperature)
- Case Study #2: Medical RF Ablation (FBGs Strain Sensors)
- Case Study #3: Medical Robotics (Position Sensors and FBG Force Sensors)
- Case Study #4: Biomedical – RF Induction Heating of Magnetic Nanoparticles (GaAs)
- Case Study #5: Food Processing – Microwave Ovens (GaAs)
- Case Study #6: Transportation – Electrical Railway Pantograph (Multi-Axis Acceleration)
- Case Study #7: Transportation – Generators and Heavy Equipment (Multi-Axis Acceleration)
- Case Study #8: Energy – Health Monitoring of Transformer and Bus Bars (Acceleration, Temperature- GaAs & FBGs)
- Case Study #9: Semiconductor – Better Process Monitoring for Better Yields (GaAs and FBGs)
- Case Study #10: Structural and System Health Monitoring (FBGs) for Reliability and Safety
- Fiber Optic Do's and Don'ts
- Summary – What we learned?
- Questions and Answers

Today's Trends in Medical, Industrial, and Aerospace drive needs for Sensors of All Types

Trend	What/Why/Where	Issue
Electrification	Reduce use of fossil fuels, lower carbon footprint, combat climate change	Creates EMI/RFI Problems
Closed Loop Processing	Automation, robotics, process & equipment health feedback for increased efficiency and lower costs	Need for variety of sensors for better process monitoring and predictive maintenance
Medical Devices	Surgical & biopsy robots, treatment delivery, MRI, patient rehabilitation	Need variety of sensors, low cost, and small size, enhance health and longevity
Harsh Environments	Transformers, generators, oil & gas, pipelines, wind turbines, underwater, nuclear	Need very robust sensors – resistant to harsh environment factors
Hazardous Locations	Food industry, chemical, mines, food & process industries	Need for intrinsically safe or inherently safe sensors
Vehicle Health	Automotive, aerospace, rail transport	For increased safety and reliability
Structural Health	Buildings, dams, highways, railroad tracks, pipelines, transmission lines	For increased safety and reliability, eliminate waste caused by leakage

Why Fiber Optics?



Immune to
Electrical and RF Fields



Immune to Lightning
and High Voltage



Radiation
Resistant



Extremely
Small Size



Transparent to
Magnetic Fields



Wide Temperature Range

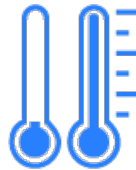

Inherently Safe



Interference-Free
Over
Long
Distances

What is a Fiber Optic Sensor?

“Remote sensing and measuring of a physical quantity using photonics for both sensing and transmission.”

Since most Fiber Optic Sensors are not of transducer⁽¹⁾ type they require an interrogator

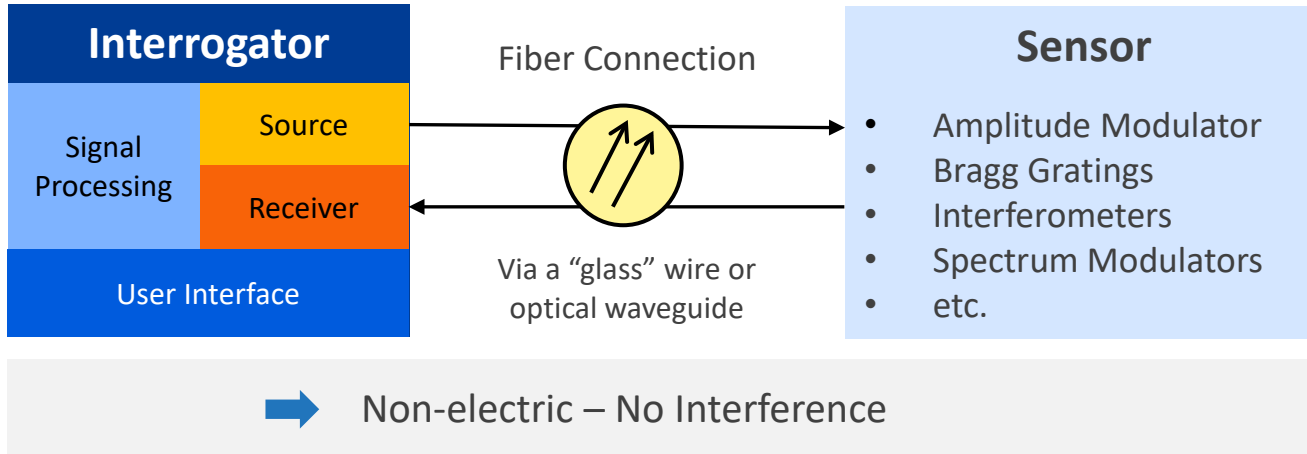

(1) transducer – a device that converts one form of energy into another.

Numerous Applications

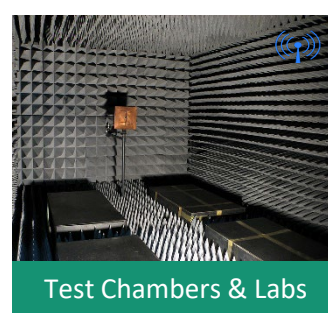
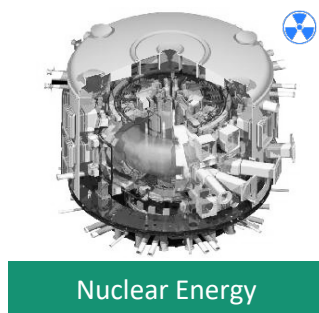
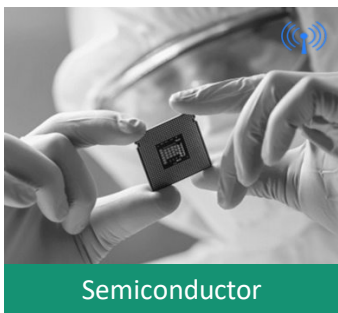

What is Fiber Optics?

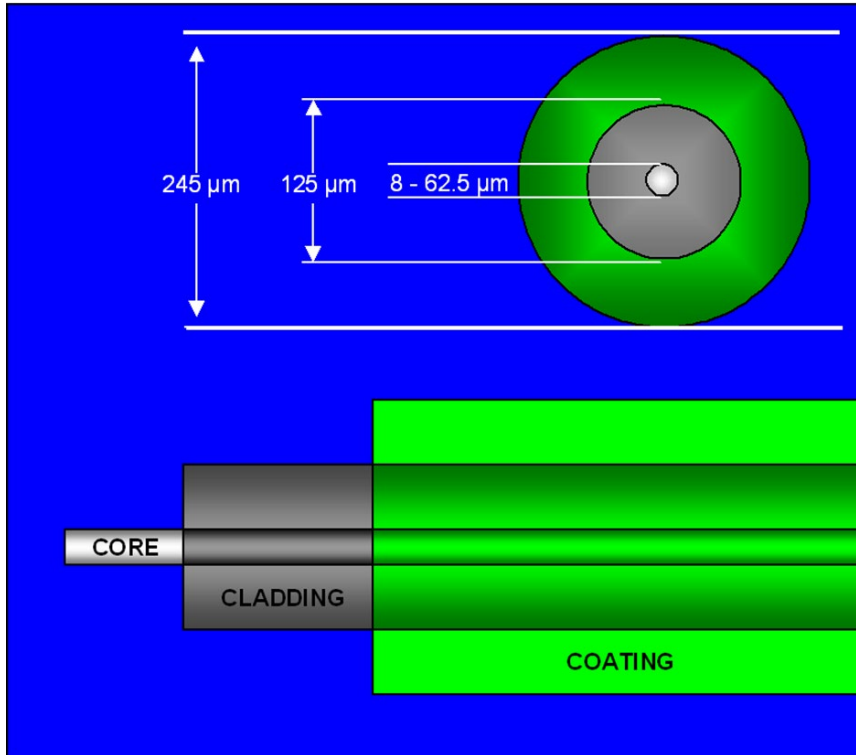

Core

- Carries the light signals
- Silica and a dopant, special pure silica core fiber
- POF uses polymer core
- 9μm for telecom SM, 5.6 μm for FiSens SM FBGs
- 50 or 62.5μm for multimode, 1mm for POF

Cladding

- Keeps light in the core
- Pure silicon or polymer

Coating

- Protects the bare fiber
- Acrylate (polymer) or Polyimide (for high temp)

What is a Mode? Singlemode versus Multimode

What is a mode? Technically, a mode is a stable propagation state in an optical fiber. Dig into mode propagation theory and you will find that it is an effect caused by the wave nature of light.

Forget the technical jargon!

Simply, a mode can be considered as a light ray, or path in an optical fiber.

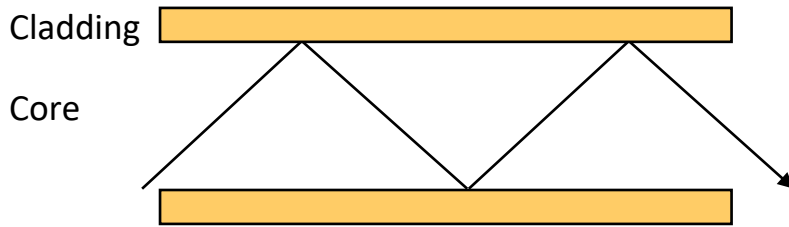

A mode in a step-index multimode fiber



A mode travelling in a singlemode fiber

An optical source can emit many modes (light rays) varying by both launch angle and wavelength. Consider how a lamp emits white light (rays) composed of all colors of the spectrum and over a wide area.

What is Fiber Optics?

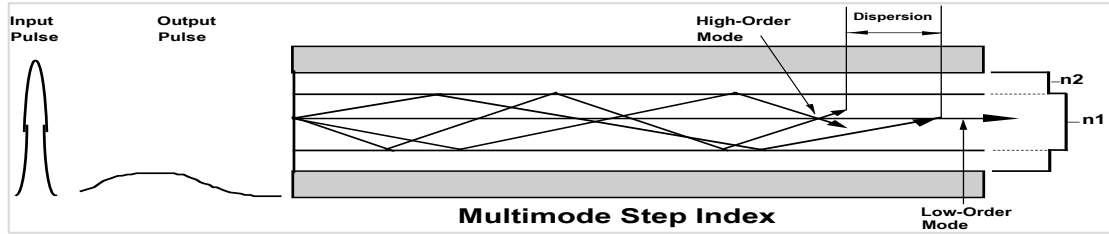

Multimode Step Index Fiber

- Short distance links, <100 m
- 10-100 Mb/s, Single λ
- POF (1mm) or HCS (200/230)

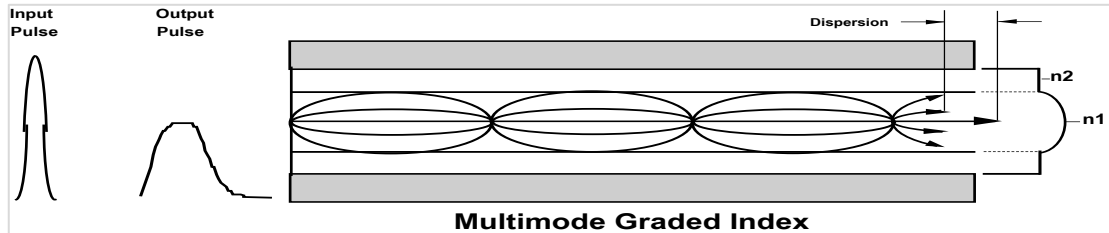

Multimode Graded Index Fiber

- Short-Medium distance links, 10m - 2000m
- 100 Mbs - 10Gb/s, Single λ
- 50/125 (OM2) or 62.5/125 (OM1/OM3)

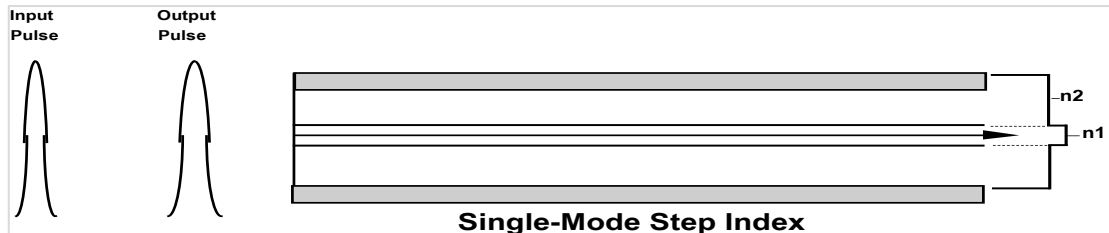

Single Mode Fiber

- Long distance links, 1000m -100km, 1300-1550nm
- 10//100/1000 Gb/s, Single λ or WDM)
- 9/125 (OS1/OS2), Specialty SMF for other λ

Fiber Optic Position Sensors

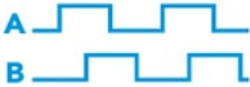

Incremental Encoder

US Patent 7,196,320

MR340
MMF-62.5/125 Series

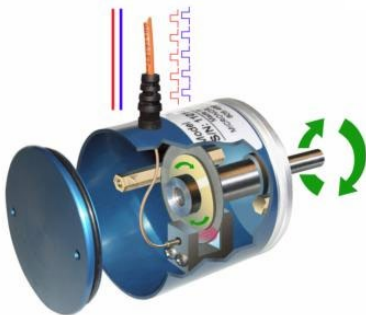
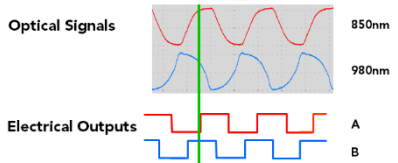
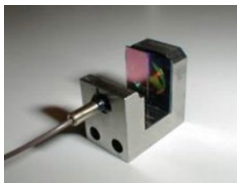

- Sensor is all-optical.
- No electronics. No power supply required.
- Sensor system consists of 3 components: passive sensor, fiber link and optoelectronic controller/converter.





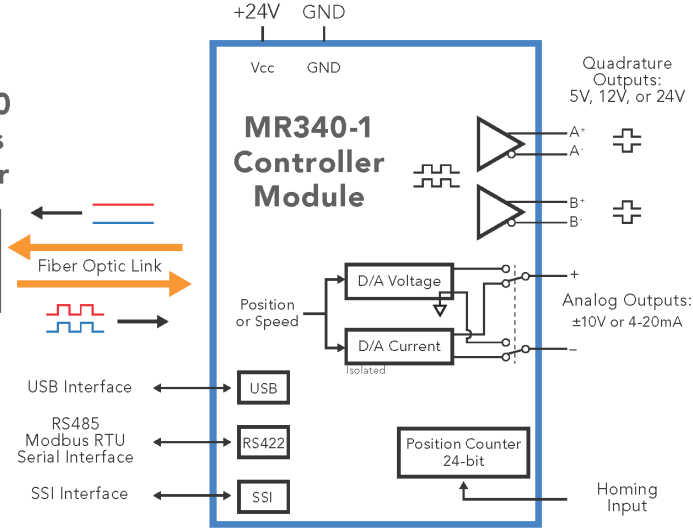



MR340 Series Sensor



FIBER OPTIC INCREMENTAL ENCODER & FO EXTENDER QUICK GUIDE



PRODUCT MODEL						
	MR340-1 Controller	TD5482 Controller in IP Housing	MR342/MR346 Shaft Encoder	MR344 Hollow Shaft Encoder	MR348 MRI Safe Shaft Encoder	MR361-1 FO Extender for non-FO Encoders
Description	Controller	MR340-1 Controller in IP Housing, with extended 30C wiring block for additional signal routing	Synchro or Flange Mount MR342: Size Ø58mm, IP64 MR346: Size Ø90mm, IP66	Size 100mm, Ø38mm Bore C Thru Bore: IP54 PC Pocket Hole: IP66	MRI Safe, Non-Metallic, Size Ø58mm, Synchro or Flange Mount	FO Transmitter/Receiver, provides interference-free extension of non-FO incremental encoders
No. of Channels or Resolution	One MR340-1 Controller interfaces to one MR34X series FO Incremental Encoder		256 or 360ppr	1024ppr	360ppr	4-Channels, typically for A/B or A/B/Z encoder interfaces
Compatible Fiber	Fiber Used OM1(62.5/125), Compatible with OM2/OM3 (50/125)					
Optical System Margin	12dB	11dB	One MR340-1 Controller controls one MR34X series FO Incremental Encoder			6dB
Maximum Distance	---	---	Up to 2000m	Up to 2000m	Up to 2000m	Up to 2000m
Encoder Output	Programmable 5V/12V/24V Level		---	---	---	RS422 or HTL option
Communications Interfaces	Analog Output, SSI, USB, ModbusRTU		---	---	---	Unused channel(s) can transmit other signals – including overspeed limit, emergency stop, etc.
Optical Interface	Duplex LC	IP-LC	Duplex LC pigtail or IP-LC	Duplex LC pigtail	Duplex LC pigtail	Simplex ST
Power Supply	24 VDC		---	---	---	5V or 10-30VDC
Accessories	FO Cabling Junction Boxes	FO Cabling Junction Boxes	---	MR344-99-XX Shaft Adapters: 8-32mm, ½" to 1¼"	---	FO Cabling Junction Boxes
RECOMMENDED PRODUCTS	MR340-1	TD5482	MR342-D06D00 MR346-D12D00	MR344-F38C1R5 MR344-F38C1R5E MR344-F38PC1R5	MR348-D06C05 MR348-D06C10	For use with HTL Encoders: MR361-1-0-3-0 (XMTR) MR361-1-1-3-0 (RCVR)

© 2023, MICRONOR SENSORS INC.
ALL SPECIFICATIONS ARE SUBJECT TO CHANGE WITHOUT NOTICE

98-0340-17-A
[QR Code to Encoders](#)



MICRONOR SENSORS, INC.
www.micronor.com

2085 SPERRY AVE, STE A-1
VENTURA, CA 93003 USA

+1-805-389-6600
sales@micronor.com



Fiber Optic Position Sensors



Absolute Encoder
 US Patent 8,461,514 B1

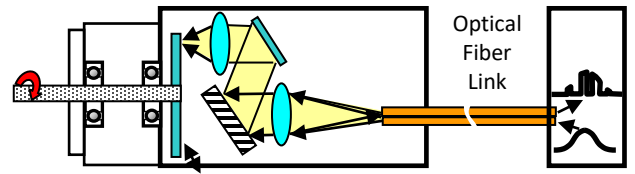

MR330
 MMF-62.5/125
 Series





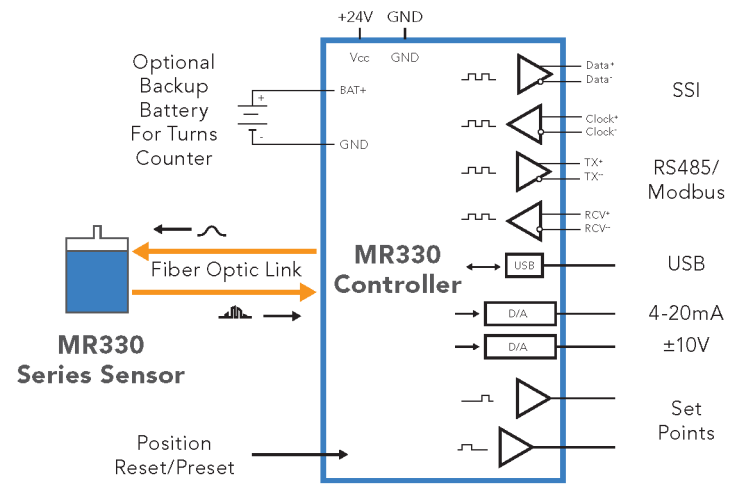



MR430
 M-POF
 Series



FIBER OPTIC ABSOLUTE ENCODER & FO EXTENDER QUICK GUIDE



PRODUCT MODEL	 MR330-1 DIN Controller	 MR332 Industrial Grade Position Sensor	 MR338 MRI Safe Position Sensor	 MR430-1 DIN POF Controller	 MR431-A06 MRI Safe POF Position Sensor	 MR361-2 FO Extender for non-FO SSI Encoders
Description	Controller	Industrial Grade Size 58mm	MRI Safe Size 58mm	Size 100mm, Ø38mm Bore C Thru Bore: IP54 PC Pocket Hole: IP66	MRI Safe, Non-Metallic, Size 11 Synchro or Flange Mount	FO Transmitter/Receiver, provides interference-free extension of non-FO incremental encoders
Resolution	Multiturn 12-bit + Single Turn 13-bit or 14-bit (13,950)			Multiturn 12-bit + Single Turn 13-bit		4-Channels, typically for A/B or A/B/Z encoder interfaces
Compatible Fiber	OM1 (62.5/125) multimode fiber interface only			1mm POF + 1mm POIF		OM1/OM2/OM3
Optical System Margin	12dB	---	---	23dB	---	6dB
Maximum Distance	---	Up to 200m	Up to 200m	---	Pigtail Lengths: 3/5/10/15/20m	Up to 2000m
Encoder Interface	SSI	---	---	SSI	---	SSI Clock+Data (RS422)
Communications Interfaces	Analog Output, SSI, USB, ModbusRTU	---	---	Analog Output, SSI, USB, ModbusRTU	---	Input Error Status (Logic)
Optical Interface	Duplex LC	Duplex LC pigtail or IP-LC	Duplex LC pigtail	MPOF	MPOF	Simplex ST
Power Supply	24 VDC	---	---	24VDC	---	5V or 10-30VDC
Accessories	FO Cabling Junction Boxes	---	---	---	Non-metallic synchro clamps	FO Cabling Junction Boxes
RECOMMENDED PRODUCTS	MR330-1	MR332-Y06D00 MR332-Y10D00	MR338-N10C05 MR338-N10C10	MR430-1	MR431-A06 sensor MR439-Pxx pigtails	For use with 10-30V Encoders: MR361-2-0-1-0 (XMTR) MR361-2-1-1-0 (RCVR)

© 2023, MICRONOR SENSORS INC.
ALL SPECIFICATIONS ARE SUBJECT TO CHANGE WITHOUT NOTICE

98-0330-23-A
[QR Code to Encoders](#)

micronor
sensors

MICRONOR SENSORS, INC.
www.micronor.com

2085 SPERRY AVE, STE A-1
VENTURA, CA 93003 USA

+1-805-389-6600
sales@micronor.com



Environmental Capabilities of Encoders & Resolvers

Environment	Resolver	Optical or Magnetic Rotary Encoder	Fiber Optic Encoders
Benign Environment	✓	✓	✓
High Temperature > +110°C	✓	✗	✓ (Up to 125°C)
Low Temperature < -45°C	✓	✗	✓
Long Distance > 50 m	✗	✗	✓
High Speed > 10,000 rpm	✓	✗	✗
EMI/RFI	✗	✗	✓
Magnetic Fields	✗	✗	✓
RF Fields	✗	✗	✓
High Voltage/Lightning	✗	✗	✓
Explosive Atmosphere	● (EX Proof required)	● (EX Proof required)	✓ (Inherently Safe)
Radiation (Nuclear)	● (Requires red-hard resolver)	✗	● (Requires rad-hard fiber)

 Recommended
 Provisional
 Not Recommended

Fiber Optic Emergency Stop and Microswitch

Operate on basic principle of photo interruption (light on / light off)

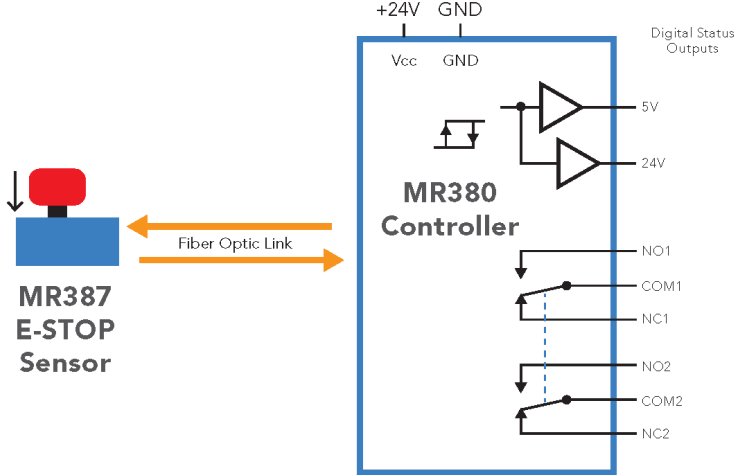
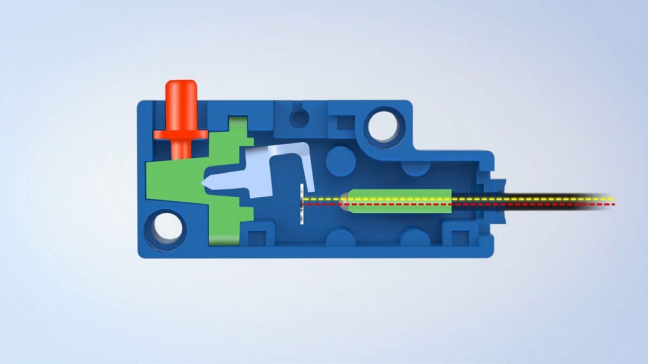
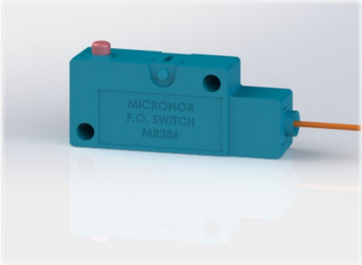

Environmental Capabilities of Microswitches







Environment	Electromechanical Micro Switch	Fiber Optic Micro Switch	Fiber Optic Emergency Stop
Benign Environment	✓	✓	✓
High Temperature > +110°C	✗	✗	✗
Low Temperature < -45°C	✗	✗	✗
Long Distance > 50m	✗	✓	✓ (Up to 18km)
EMI/RFI	✗	✓	✓
Magnetic Fields	✗	✓	✓
RF Fields	✗	✓	✓
High Voltage/Lightning	✗	✓	✓
Explosive Atmosphere	● (Ex Proof Required)	✓	✓

 Recommended

 Provisional

 Not Recommended

FIBER OPTIC SIGNALING SENSORS – EMERGENCY STOP & MICROSWITCH

PRODUCT MODEL						
	MR380-0-UNI OEM Controller	MR380-1-3 DIN Controller	MR386 FO Microswitch	MR387 MM/SM FO E-Stop	MR388 Outdoor FO E-Stop	TD5412 POF E-Stop
Description	Universal SM/MM OEM Controller (PCB)	Universal SM/MM DIN Rail Controller	V-series compatible Microswitch	Emergency Stop, Pigtail or IP66 housing	MR387 E-Stop in IP67 Weatherproof Enclosure	POF E-Stop
No. of Channels	1 (Duplex)	1 (Duplex)	Multiple sensors can be wired in series up to the limits of the Controller's optical loss margin. Consult application note AN118 for link examples and calculations.			1 (Duplex)
Compatible Fiber	OM1 (MM 62.5/125) OM2/OM3 (MM 50/125) OS1 (SM 9/125)		Available with OM1 pigtail only. Compatible with OM2/OM3 fiber links.	Available with OM1 or OS1 fiber interfaces only. OM1 interfaces compatible with OM2/OM3 fiber links.	Available with OM1 or OS1 fiber interfaces only. OM1 interfaces compatible with OM2/OM3 fiber links.	1mm POF
Optical System Margin	OM1=21dB, OS1=18dB	23dB	Use with MR380	Use with MR380	Use with MR380	User provides 650nm (red) optical interface
Maximum Distance	Depends on # of sensors wired in series, # of interconnections, and cable segment lengths		Up to 12km	MM, up to 13km SM, up to 18km	MM, up to 13km SM, up to 18km	Up to 20m
Function Safety Rating	Not rated	SIL=1, PL=c	Not rated	SIL1/PLc when used with MR380-1-3 Controller	SIL1/PLc when used with MR380-1-3 Controller	Not rated
Digital Status Outputs	5V Logic, OC	5V & 24V Logic	---	---	---	---
Internal Relay	---	DPDT contacts	---	---	---	---
Optical Interface	Duplex LC	Duplex LC	Duplex LC pigtail	Duplex LC pigtail, or IP-LC receptacle	Internal: Duplex LC External: IP-LC receptacle	Duplex 1mm POF
Power Supply	5-24 VDC	24 VDC	---	---	---	---
Accessories	---	---	Compatible with Omron and Honeywell V-series lever arm accessories	---	---	---
RECOMMENDED PRODUCTS	MR380-0-UNI	MR380-1-3	MR386-21-1R5 (NO) MR386-25-1R5 (NC)	MR387-2S-1R5 (MM) MR387-2S-D00 (MM) MR387-3S-1R5 (SM) MR387-3S-D00 (SM)	Special Order	TD5412

© 2023, MICRONOR SENSORS INC.
ALL SPECIFICATIONS ARE SUBJECT TO CHANGE WITHOUT NOTICE

98-0380-22-A
[QR Code to MR387](#)

micronor
sensors

MICRONOR SENSORS, INC.
www.micronor.com

2085 SPERRY AVE, STE A-1
VENTURA, CA 93003 USA

+1-805-389-6600
sales@micronor.com



Fiber Optic Acceleration/Vibration Sensors

A dedicated MEMS membrane/mirror is aligned with a specific axis and light is modulated only by that axis.

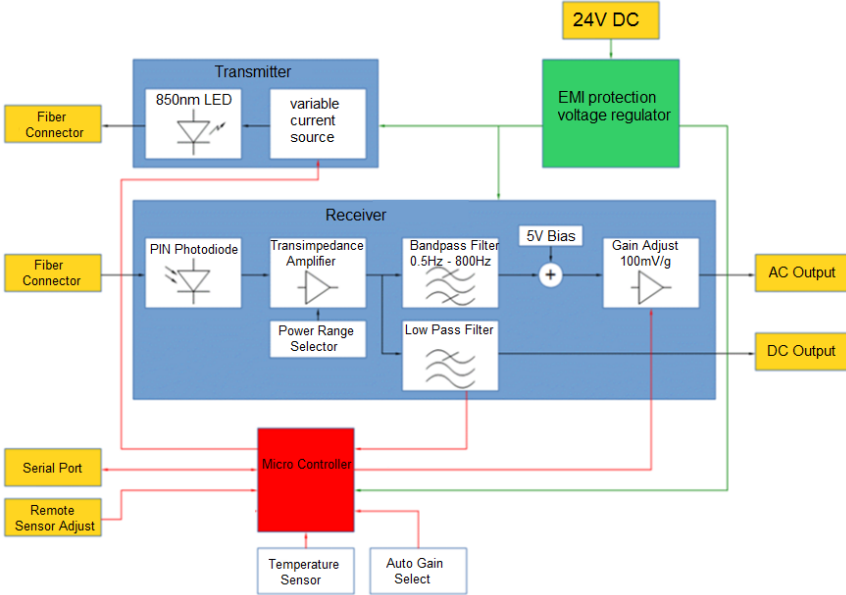
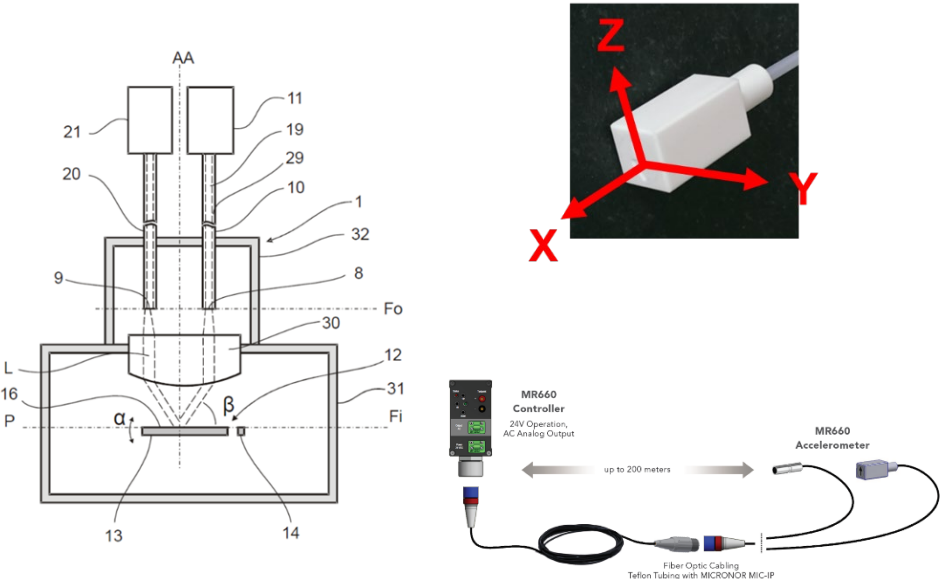

Multi-Axis FO Acceleration/Vibration Sensors

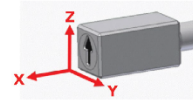

MODEL	MR661 1-Axis, Round	MR662 1-Axis, Rectangular	MR663 2-Axis	MR664 3-Axis	MR660 Signal Conditioners	ISOLATOR For >5kV
Key Features	General Purpose 100% passive design, immune to magnetic and electric fields				AC output per axis	High isolation for HV Rail Systems
Applications	Electric Train Pantograph, Transformers, Generators, Heavy Equipment, Medical, MRI (in ceramic housing)				Vibration Analysis	For pantograph applications where addition cabin/pantograph isolation is required
Measurement Range	0-50 g, Minimum Frequency= 0.5 Hz, Max Frequency= 1100 Hz (-3dB BW) Linearity= 3% max, Max Shock 1500 g				Output= 100mv/g pk-pk Non-Linearity= 5% max	+180 °C Max
Operating Temperature	Operating= -40 °C to +85 °C, Storage= -40 °C to +155 °C				-40 °C to +85 °C	---
Housing	Aluminum	Standard Aluminum or Optional Ceramic			Aluminum	---
Length	6m	6m	6m	6m	---	---
Cable Jacket	Polyimide / Teflon	Polyimide / Teflon	Polyimide / Teflon	Polyimide / Teflon	---	---
Connector Type	FO4	FO4	FO4	3x Duplex-E2000	BNC Output(s)	Dual FO4, supports two 1-axis or 2-axis sensors only
STANDARD PRODUCTS	MR661 6099.26.180 (Mtg Adapter)	MR662	MR663	MR664	MR660-1 (for MR661/MR662) MR660-2 (for MR663) MR660-3 (for MR664)	9800.03.007 (25kV) 9800.03.002 (50kV)

© 2023-2024, MICRONOR SENSORS INC.,
ALL SPECIFICATIONS ARE SUBJECT TO CHANGE WITHOUT PRIOR NOTIFICATION.

98-0660-03-A
[QR Code to MR660 Sensors](#)



MICRONOR SENSORS, INC.
www.micronor.com

2085 SPERRY AVE, STE A-1
VENTURA, CA 93003 USA

+1-805-389-6600
sales@micronor.com



Gallium Arsenide (GaAs) Thermometry

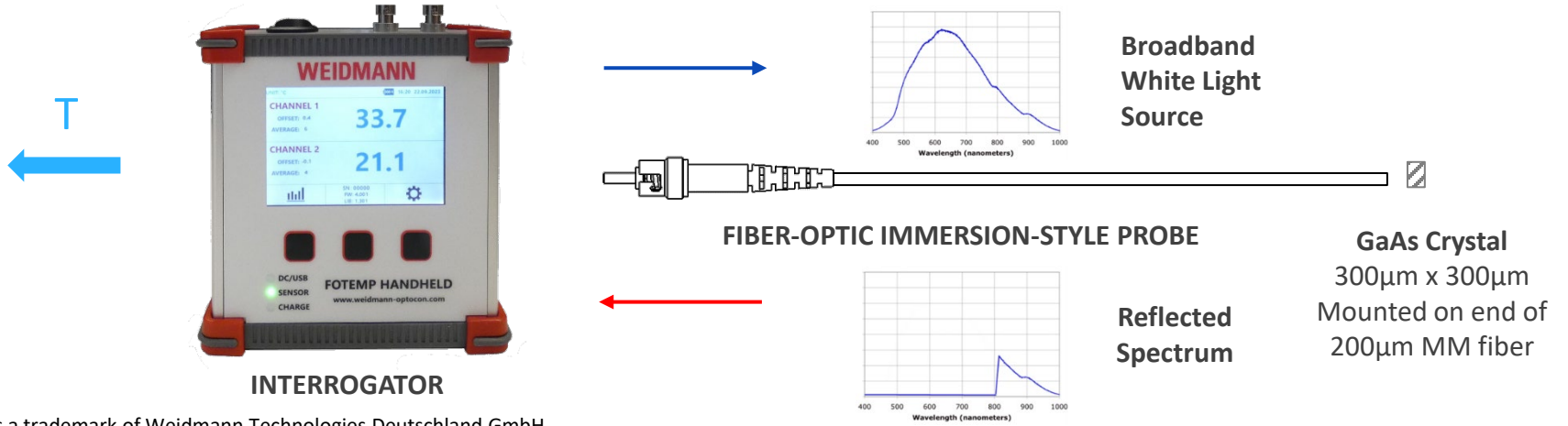

Optocon® is a trademark of Weidmann Technologies Deutschland GmbH

Principles of Operation

1. GaAs is a non-metallic semiconductor crystal in which the effect of temperature is based on the inherent light absorption and transmission properties of the crystal.
2. Light source transmits light to the crystal. Some of the light is absorbed and the rest is reflected back to the spectrometer.

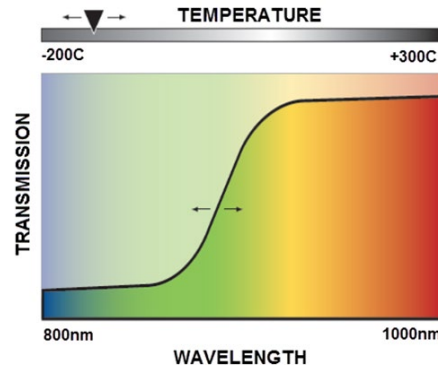

Optical beam probes the wavelength dependence of the intrinsic band-gap of GaAs which is dependent on absolute temperature.

$$E_{\text{gap}} = 1.423\text{eV}$$



$$\Rightarrow 300^{\circ}\text{K} = 872\text{nm}$$

$$dE_{\text{gap}}/dT = -0.452\text{meV}/^{\circ}\text{K}$$

$$\Rightarrow \approx 0.315\text{nm}/^{\circ}\text{K}$$

FOTEMP® FO TEMPERATURE PROBES

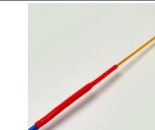
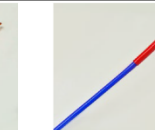
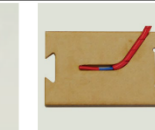

MODEL	 TS2p Smallest	 TS3 General Purpose	 TS4 Harsh Chemicals	 TS5 Medical & SFF	 TST Transformers	 SmartSpacer® SmartDisc, & Busbar
Key Features	Smallest size, Bare GaAs crystal (300µm x 300µm) for Very Small Surface Areas, Semi devices, and Micro-Vials, Non-Conductive.	Semi Rigid Probe, Immune to EMI/RFI and Microwave Emissions, Non-Conductive.	High Accuracy, Corrosion Resistant, PTFE Coated, Non-Conductive.	Flexible Probe, Small Form Factor, and Compact Size, Non-Conductive.	Specifically Designed for Use in Oil-Filled & Dry Transformers, Non-Conductive	Non-conductive accessories used to embed TST and TS3 probes in transformer, busbar and switchgear.
Applications	General Use: RF, Voltage, Semiconductor Device, and Medical Testing	General Use: Food, Microwave Oven, and RF Environments	Harsh Chemical and Liquid Immersion	Medical Environments, Catheter Instrumentation, Semiconductor, Small FF	Oil-Filled Transformers	General Use: Transformer Windings, Bus Bars, & other Switchgear.
Temperature Range	-200 °C to +300 °C	-200 °C to +300 °C	-200 °C to +300 °C	-200 °C to +300 °C	-40 °C to +200 °C	+180 °C Max
Accuracy	± 0.2 °C	± 0.2 °C	± 0.2 °C	± 0.2 °C	± 0.2 °C	---
Thermal Response	20 °C/s	12 °C/s	7 °C/s	19 °C/s	19 °C/s	---
Probe Dimensions	D1: 0.25 mm D2: 1.7 mm D3: 1.3 mm	D1: 1.0 mm D2: 1.7 mm D3: 1.3 mm	D1: 1.0 mm D2: 1.7 mm D3: 1.3 mm	D1: 0.6 mm D2: 2.0 mm D3: 1.3 mm	D1: 1.75 mm D2: 1.2 mm D3: 3.1 mm	SmartSpacer & SmartDisc for use with TST probe. SmartBusbar used with TS3 probe.
Dimensions Other lengths on request	L1: 4 mm L2: 10 mm L3: 1 – 20 m	L1: 10 – 130 mm L2: 30 mm L3: 1 – 20 m	L1: 15 – 550 mm L2: 10 mm L3: 1 – 20 m	L1: 10 – 600 mm L2: 15 mm L3: 1 – 20 m	L1: 10 mm L2: 70 mm L3: 1 – 20 m	Consult drawings
Cable Coating	Polyimide / Teflon	Polyimide / Teflon	Polyimide / Teflon	Polyimide / Teflon	Polyimide / Teflon	PEEK or NOMEM
Connector Type	ST	ST	ST	ST	ST	---
STOCK PRODUCTS (L1 and L3 Lengths)	TS2p-02	TS3-15MM-02 TS3-15MM-06	TS4-15MM-02	TSS-20MM-02, -06 TSS-50MM-02, -06	Special Order based on required lengths	EOF0200 SmartSpacer EOF0203 SmartDisc ZM0060 SmartBusbar

© 2023-2024, MICRONOR SENSORS INC., FOTEMP® is trademark of COMEN Group, SmartSpacer® is trademark of WEIDMANN HOLDING AG
ALL SPECIFICATIONS ARE SUBJECT TO CHANGE WITHOUT PRIOR NOTIFICATION.

98-OPTC-27-D1
[QR Code to TS sensors](#)



MICRONOR SENSORS, INC.
www.micronor.com

2085 SPERRY AVE, STE A-1
VENTURA, CA 93003 USA

+1-805-389-6600
sales@micronor.com



FOTEMP® FIBER OPTIC SIGNAL CONDITIONERS

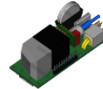

MODEL	FOTEMP-PLUS Most Popular	FOTEMP-H2 Handheld	FOTEMP-OEM	FOTEMP-MINI 3	FOTEMP-T2	FOTEMP-MODULAR
Description	Compact Bench Top	Handheld, Portable	OEM Module, Bench Top, Chassis or DIN Rail Mount	Small Form Factor OEM PCB Module	DIN Rail, Chassis Mount or Bench Top	Multichannel Modular System
No. of Channels	1, 2 or 4	1 or 2	1, 2 or 4	1	4, 8, 12, or 16	1-255
Measurement Range	-200 °C to +300 °C	-200 °C to +300 °C	-200 °C to +300 °C	-200 °C to +300 °C	-200 °C to +300 °C	-200 °C to +300 °C
Accuracy	± 0.3 °C	± 0.2 °C	± 0.2 °C	± 0.2 °C	± 1 °C	± 0.2 °C
Applications	Laboratory, Industrial, Process Monitoring	Laboratory, Industrial, Process Monitoring	Industrial Process, Switchgear, Generator, Transformer	Embedded OEM Application	Industrial Process, Switchgear, Generator, Transformer	Laboratory, Process Monitoring
Sample Rate/channel	250ms	250ms	250ms	250ms	250ms	250ms
Internal Data Logging?	No	Yes	No	Yes	Yes Requires programming via Modbus	No
Data Logging Storage	---	MicroSD Card	---	MicroSD Card	MicroSD Card	---
Analog output	Std=0-10V Option=4-20mA	---	Std=0-10V Option=4-20mA	---	Std=4-20mA (First 8 Channels Only)	Option: 0-10V or 4-20mA
Relay output	Option=4	---	Option=4	---	Std=4	Option=1-255
Interface	Std=USB+RS232 Option=USB+RS485	USB-C	Std=USB+RS232 Opt=USB+RS485/Modbus	USB-C, UART, RS232, RS485/ModbusRTU	Std=USB+ModbusRTU Option=USB+ModbusTCP	RS485 or RS232
Power Supply	12VDC (includes AC power supply)	12VDC or USB-C, (Internal Li-Ion battery)	12 VDC (includes AC power supply)	USB-C (5V 3A)	24VDC (includes DIN AC-DC Power Supply)	100-240VAC
STOCK PRODUCTS A1-CAL= -20C to +150C A2-CAL= -40°C to +200C B-CAL= -40°C to +300°C C-CAL= -200°C to +300°C	FOTEMP4-PLUS-P0-V-B FOTEMP4-PLUS-P0-V-C	FOTEMP-H2-1-P0-A2 FOTEMP-H2-2-P0-A2	Special Order	FOTEMP-MIN3-P0-A2 Special Order	FOTEMP-T2-8-P1-B	Special Order

© 2023-2024, MICRONOR SENSORS INC., FOTEMP® and OPTOCON® are registered trademarks of COMEN Group
ALL SPECIFICATIONS ARE SUBJECT TO CHANGE WITHOUT PRIOR NOTIFICATION.

98-OPTC-28-D1
[QR Code to FOTEMPs](#)



MICRONOR SENSORS, INC.
www.micronor.com

2085 SPERRY AVE, STE A-1
VENTURA, CA 93003 USA

+1-805-389-6600
sales@micronor.com<https://www.micronor.com>



Multipoint sensing via Fiber Bragg Gratings (FBG)

FiSens® FBG System: Interrogator + Fiber Sensor Chain

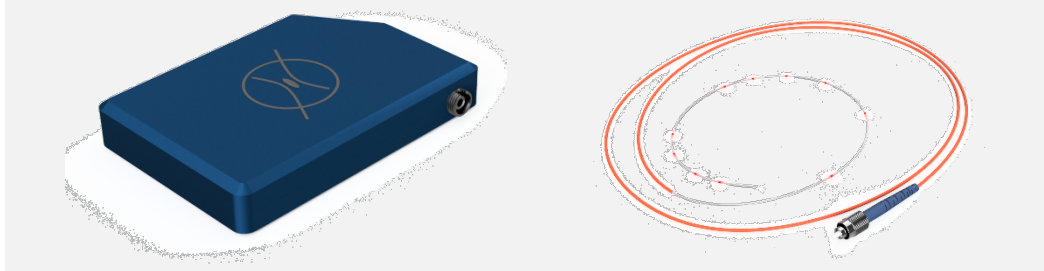

FiSens® is a trademark of FiSens GmbH

Principles of Operation

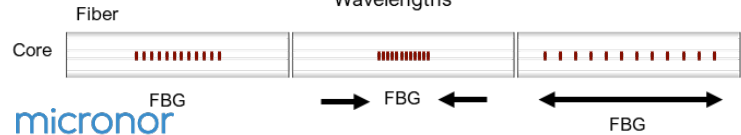
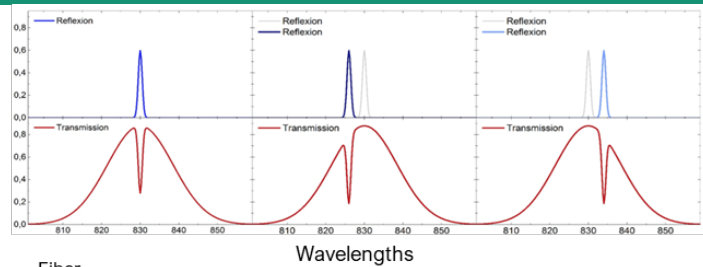

1. Ultra-short femto-second laser pulses create high-precision nanoscopic FBG structures into the core of a single mode fiber
2. Multiple FBGs can be written anywhere along the length of the fiber, each tuned to a specific wavelength signature.
3. **Thermal and mechanical force** induce change in the specific reflected FBG wavelengths.
4. FBG Interrogator (integrated light source and spectrometer) analyzes the wavelength shift and converts to temperature or strain.

Single and Multipoint Sensing - FBGs

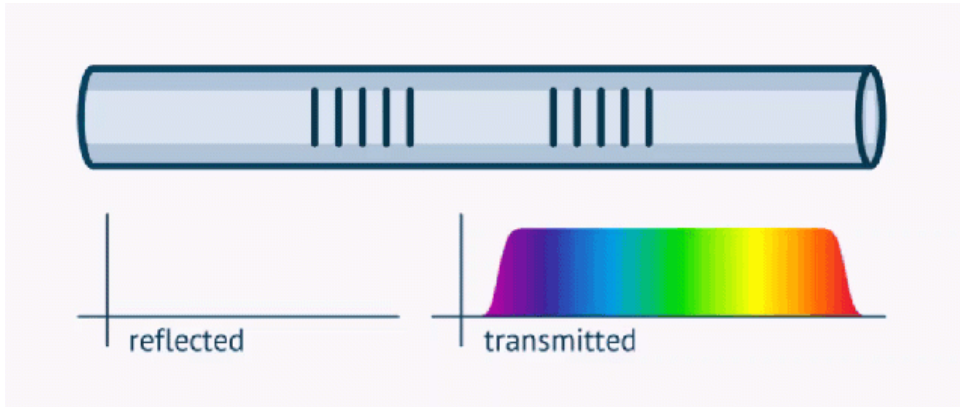

Reflected wavelength of a particular FBG is a function of both temperature and strain on that FBG.

For FiSpec FBGs and interrogators operating at in the 850nm window, the Reflected Wavelength equals Bragg Wavelength which corresponds to 21°C and 0 $\mu\epsilon$ ($\mu\text{m}/\text{m}$).

Theory of Fiber Bragg Grating Sensors

Wikipedia-Fiber Bragg Gratings

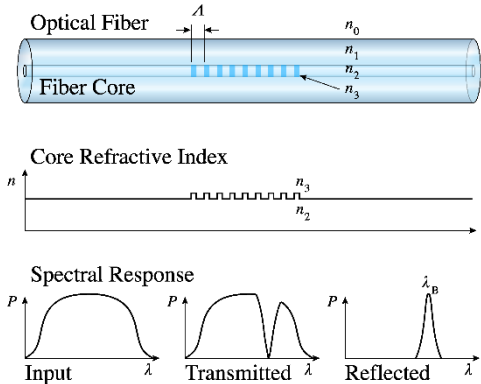

Figure 1: A Fiber Bragg Grating structure, with refractive index profile and spectral response.

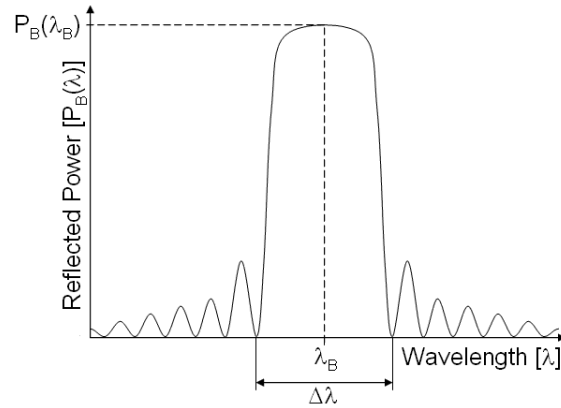

Figure 2: FBG reflected power as a function of wavelength

$$\lambda_B = 2n_e \Lambda$$

The reflected wavelength (λ_B), called the Bragg wavelength, is defined by this relationship, where n_e is the effective refractive index of the fiber core and Λ is the grating period. The effective refractive index quantifies the velocity of propagating light as compared to its velocity in vacuum.

The Bragg wavelength is sensitive to both strain and temperature. The relative shift in the Bragg wavelength $\Delta\lambda_B/\lambda_B$, due to applied strain ϵ and and a change in temperature ΔT is approximately given by:

$$\left[\frac{\Delta\lambda_B}{\lambda_B} \right] = C_S \epsilon + C_T \Delta T$$

or,

$$\left[\frac{\Delta\lambda_B}{\lambda_B} \right] = (1 - p_e)\epsilon + (\alpha_\Lambda + \alpha_n)\Delta T$$

where:

C_S is the coefficient of strain and related to the strain optic coefficient p_e ; and

C_T is the coefficient of temperature, which is made up of the thermal expansion coefficient of the optical fiber α_Λ and the thermo-optic coefficient α_n .

FBG Temperature and Strain Application Guidelines

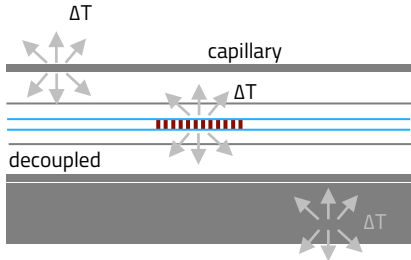
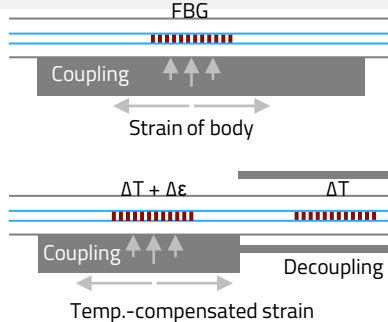
Parameter	Temperature, T	Strain, ϵ
Geometry	Strain-relieved bare fiber or rigid capillary	Bare fiber
Mounting	Inside capillary, secure in machined channel, secure with Kapton tape	Embedded in material, glued to surface
Challenges	Strain also enlarges FBG	Temperature affects refractive index of the FBG, enlarges FBG
Solutions	Choose geometry to avoid strain-related effects	Compensate for thermal expansion with 2 nd FBG
Typical Applications	Structural health, wind turbine, switchgear, winding hot spot, injection molding	
		

FBG Measurement Applications

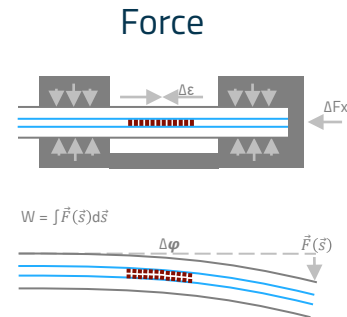
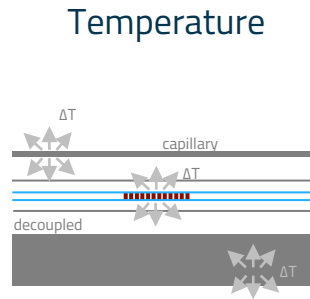
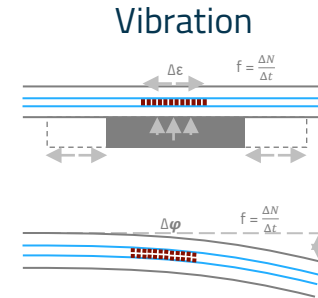
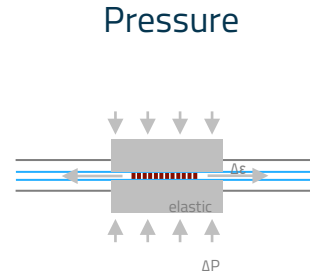
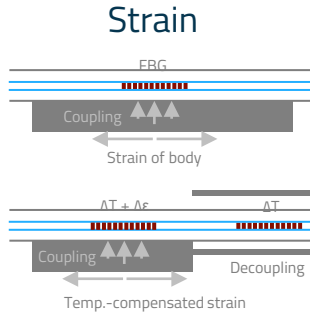

FiSens FiSpec 850nm FBG Sensing System

1/10 the size and 1/4 the cost while maintaining highest performance



Flagship FiSpec FBG Interrogators (850nm Window)

FBGX100 and 4-Channel FBGX400

Radical innovative design for mass market FBG-analysis



- Worldwide smallest and most economical interrogation system for mutple FBGs (array) with embedded light source
- Interrogate up to 30 FBGs per channel, Wideband, 808-880nm
- Sampling rate 1-100 Hz (applies to all FBGs)
- Measurement precision : 0.1° or 1µe (at 1Hz)
- Digital Measurement Resolution: 0.001°C or 0.01µe
- Interfaces: Micro-USB, 3.3V UART Port

Exemplary FBG Spectrum @ 850nm

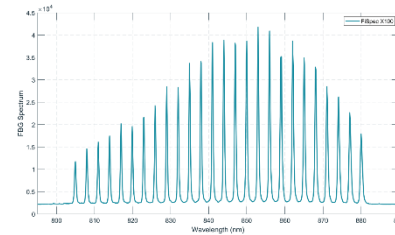

Precision vs. Sampling Rate
Noise level (2σ)

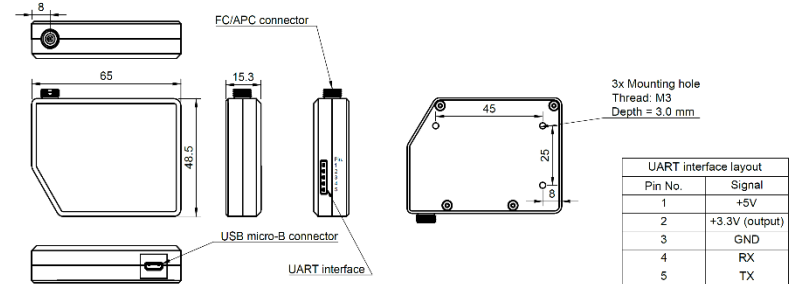
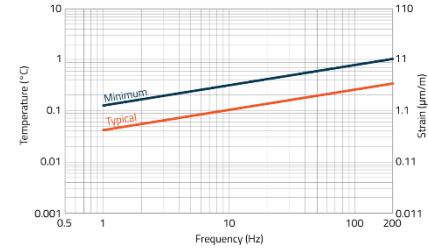

High Precision, Fast Interrogation: FBGX1000-X

Fast FBG-interrogation



Exemplary FBG Spectrum @ 850nm

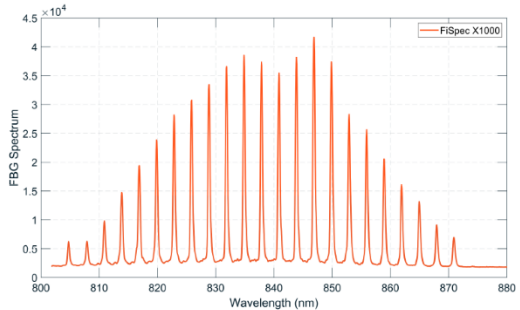

Precision in (μe) vs. Sampling Rate (Hz)

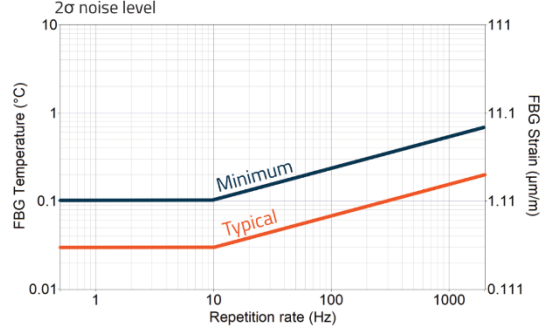

- 1 Channel with multiple (optically combined) ports depending on model (FBGX1000-2 =2 ports, FBGX1000-4 =4 ports)
- Interrogate up to total of 24 Narrow-Band FBGs, 808-868nm, multiple FBG sensor chains will require special C-parameter wavelength assignments so that FBGs do not spectrally overlap.
- Sampling rate: 1-2000 Hz
- Measurement precision : 0.1°C or 1μe (at 1kHz)
- Digital Measurement Resolution: 0.01°C or 0.01μe
- Interfaces: Micro-USB, RS485/ModbusRTU, Ethernet

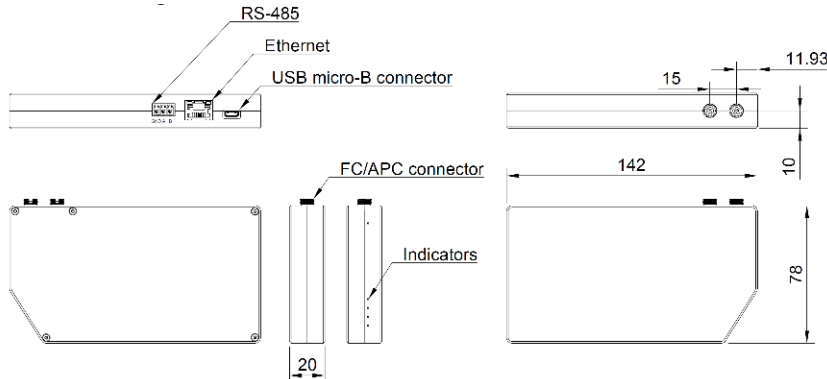

How To Choose An Interrogator:

FBGX100 vs FBGX1000 series, Precision versus Sampling Rate

FBGX100 Series

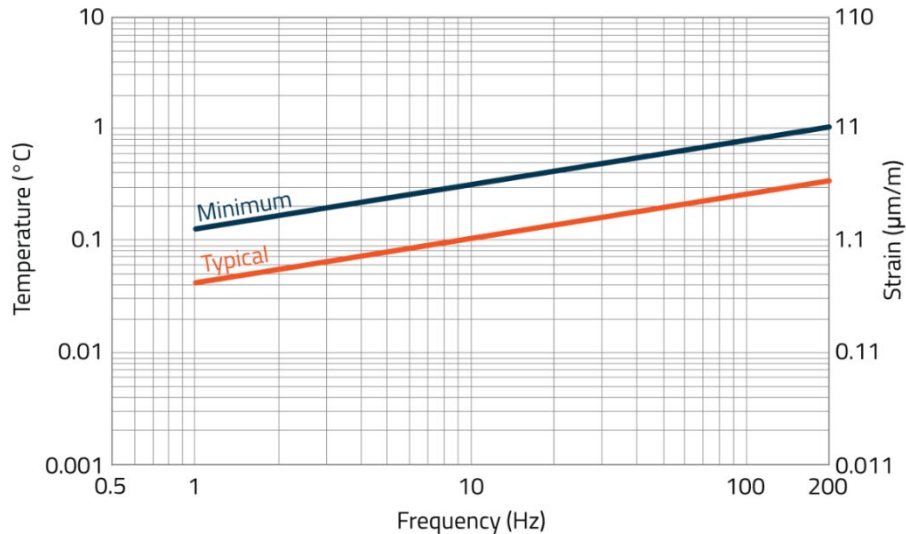

FBGX1000 Series

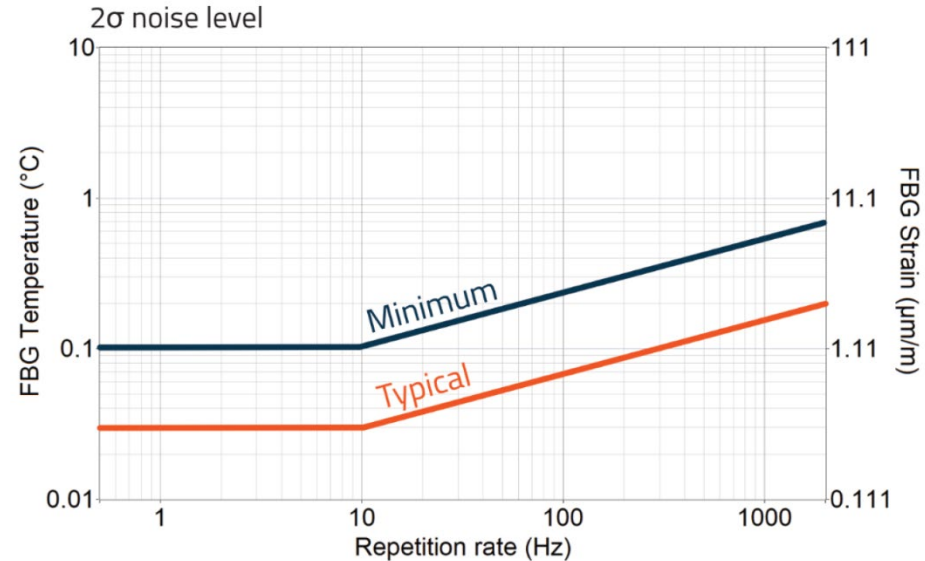

Hint: Lower sampling rate maximizes precision, wider pulse provides higher power & SNR

How to read & log temperature/strain data

- FiSens **FBG-Interrogator** software is general purpose research tool based on LabView® Runtime and provided FREE. Provides data visualization and data logging functions. It recognizes multiple as well as multichannel interrogators.

- Data logging mode outputs an Excel-compatible tab-delimited CSV file.

- Wideband FBGX100 series (max 30 FBGs per sensor chain) provides built-in microUSB and TTL UART interfaces.

- Narrow Band FGBX1000 series (max 25 FBGs per sensor chain, available 4Q2023) provides built-in microUSB, RS485 and Ethernet interfaces.

- For integration of interrogator communicaditons into customer software, program code examples are provided in NI LabView®, C and Python.

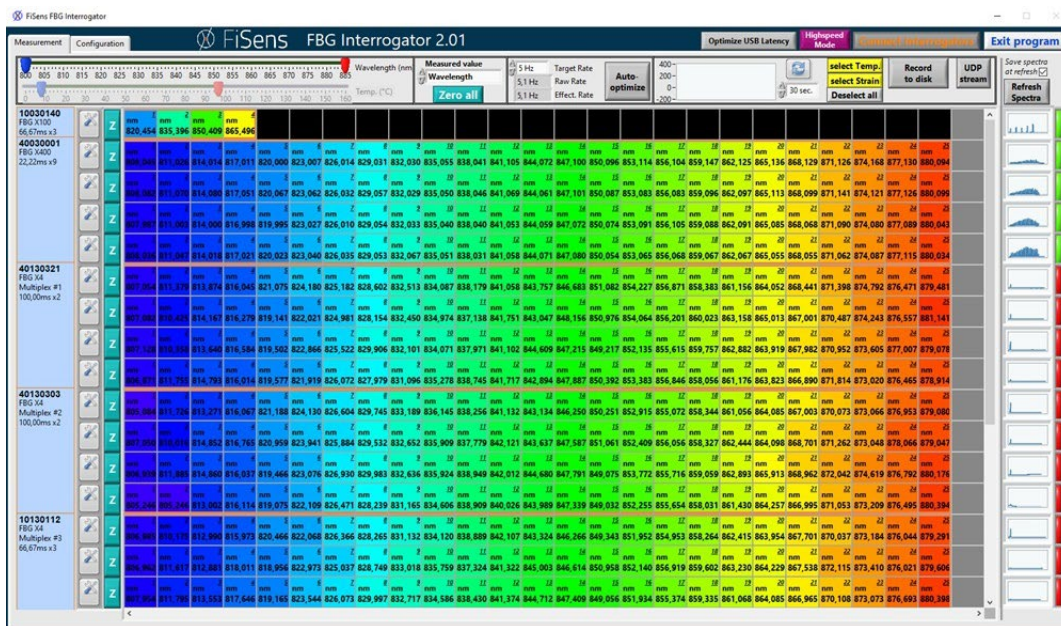

Tab delimited data. Strain: [S]= $\mu\text{m}/\text{m}$; Temperature: [T]= $^{\circ}\text{C}$; Wavelength: [W]=nm; Intensity: [I]=ct.

```
Time (YYYYMMDDHHMMSS.SSS) 10020179/-/1/T1 10020179/-/1/S2 40020423/-/2/T5
20220330092516,9141 31,8400 75,2739 30,9000
20220330092517,8984 32,0700 76,8101 30,8100
```

How To Specify a FiSens FBG Sensor Chain

Up to 30 FBG at arbitrary Positions

Position Tolerance: 0,3%/m

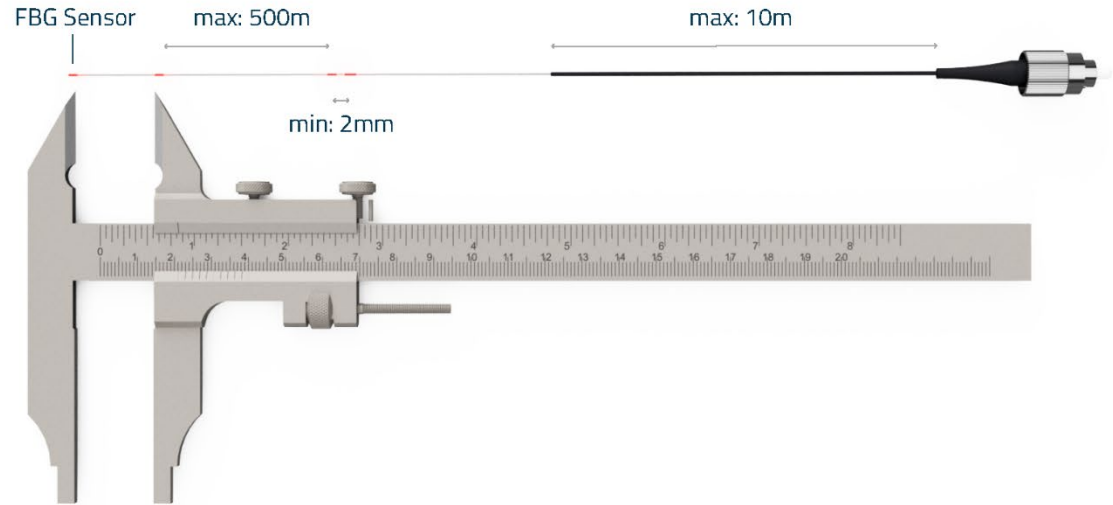

How To Specify an FBG Sensor Chain

Step 1

(A) FBG Array Part Number

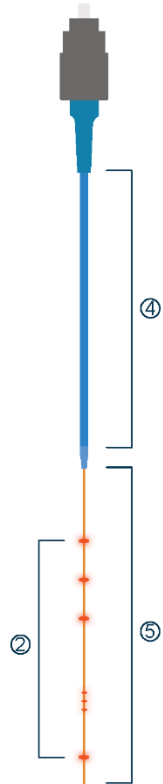

- ① **Sensor Type**
 P - Polyimide
 A - Acrylate
 UHS - Ultra-High Strength
 UHT - Ultra-High Temp

- ③ **Spectral Range**
 N - Narrow [808-865]
 W - Wide [808-880]
 C - Custom

- ⑤ **Sensor Capillary**
 FI - Bare Fiber
 PK - PEEK Tubing
 SSC - SS Capillary
 SI - Silica Capillary
 HY - Hytrel Tubing
 AC - Alumina Ceramic

P - 5 - N - GL - FI

- ② **FBG Quantity**
 1 - 1 FBG
 2 - 2 FBGs
 ...
 30 - 30 FBGs

- ④ **Lead-in Protection**
 GL - Glass Textile
 SST - SS Flexible Tube
 HY - Hytrel Buffer
 LSZ - Standard Telecom

① Sensor Type

	Fiber	Application	Operating Temperature	Capillary Options (5)
P	SM800, Polyimide Coating	Strain, Temperature	-250...+300C	FI, PK, SSC, SI, HY
A	SM800, Acrylate Coating	Temperature	-40...+80C	FI, HY, PK
UHS	Pure Silica Core, Polyimide Coating	Strain	-250...+300C	FI
UHT	Pure Silica Core, No Coating	Temperature	-250...+800C	SSC, SI, AC

③ Wide Spectral Configuration [for X100-X400]

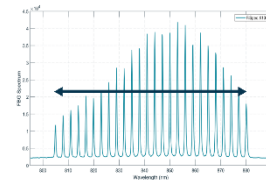

Narrow Spectral Configuration [for X1000-X4000]

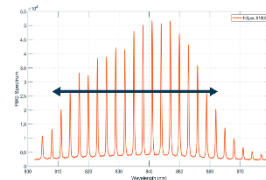

How To Specify an FBG Sensor Chain

Step 1

A FBG Array Part Number

- ① **Sensor Type**
 P - Polyimide
 A - Acrylate
 UHS - Ultra-High Strength
 UHT - Ultra-High Temp
- ② **FBG Quantity**
 1 - 1 FBG
 2 - 2 FBGs
 ... - 30 - 30 FBGs
- ③ **Spectral Range**
 N - Narrow [808-865]
 W - Wide [808-880]
 C - Custom
- ④ **Lead-in Protection**
 GL - Glass Textile
 SST - SS Flexible Tube
 HY - Hytrel Buffer
 LSZ - Standard Telecom
- ⑤ **Sensor Capillary**
 FI - Bare Fiber
 PK - PEEK Tubing
 SSC - SS Capillary
 SI - Silica Capillary
 HY - Hytrel Tubing
 AC - Alumina Ceramic

P - 5 - N - GL - FI

④ SST - Stainless Steel (1.4301) Corrugated Tube

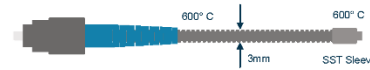

GL - Glass Textile

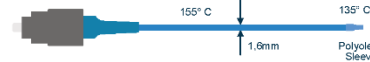

⑤ FI - Bare Fiber with Polyimide Coating

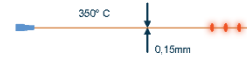

SI - Silica Capillary

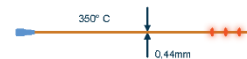

LSZ - Low Smoke Zero Halogen

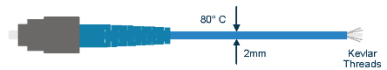

HY - Hytrel Buffer

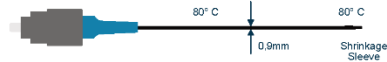

SSC - Stainless Steel (1.4301) Capillary

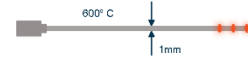

PK - PEEK Tubing

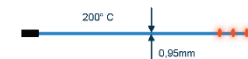

AC - Alumina Ceramic

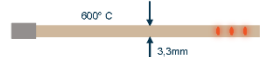

HY - Hytrel Tubing

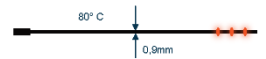

How To Specify an FBG Sensor Chain

Step 2

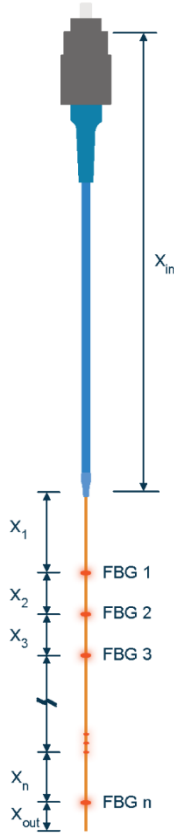

Ⓑ FBG Array Distance Code

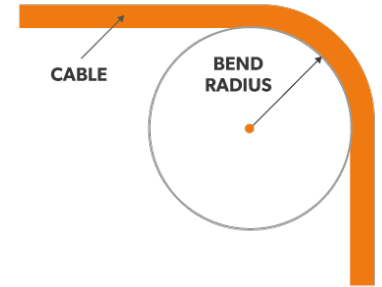
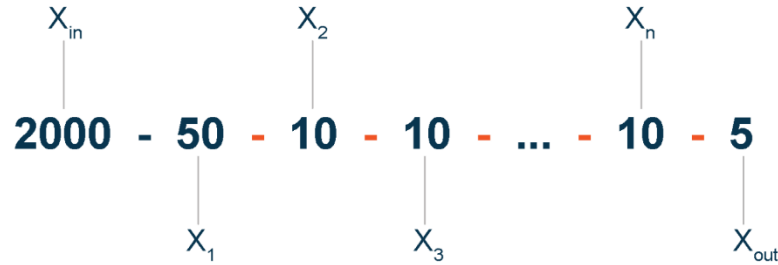

Length/Bending Limitations

	4. Lead-in Protection				5. Sensor Capillary				
	SST	LSZ	GL	HY	FI	SSC	SI	PK	AC
Crit. Bending Radius	15mm	10mm	5mm	5mm	5mm	100mm	20mm	40mm	-
Max length	10m	10m	5m	5m	500m	3m	2m	10m	1m
Min length	0,5m	0,5m	200mm	20mm	20mm	100mm	50mm	50mm	100mm

How To Specify an FBG Sensor Chain Step 3 (Optional)

Ⓒ Customized FBG Wavelength Code (only if custom sensor type: “C”)

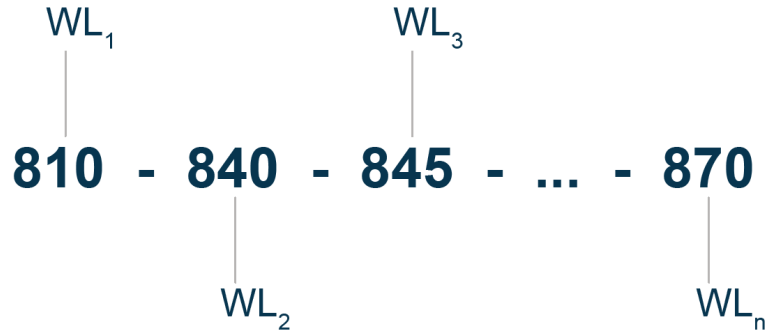

CWL Tolerance: 0,15nm

CWL Range: 800-900nm

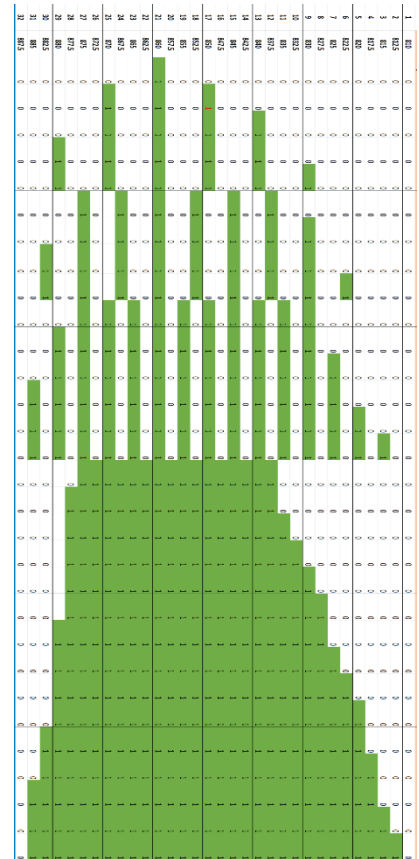

FISENS® FBG INTERROGATOR & SENSOR CHAIN QUICK GUIDE

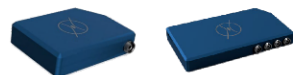

MODEL	FBGX100 Interrogator	FBGX400 Interrogator	FI Sensor Chain Bare Fiber Capillary	PE Sensor Chain PEEK Capillary	SI/AC Sensor Chain SI=Silica, AC=Al Ceramic	SSC Sensor Chain Stainless Steel Capillary
Description	Compact Interrogator	Compact Interrogator	Bare Fiber, SM800 P=Polyimide-coated A=Acrylate-coated	Bare Fiber mounted in PEEK tubing	Bare Fiber mounted in Silica or Alumina Ceramic Capillary Tube	Bare Fiber mounted in Stainless Steel Capillary Tube
No. of Channels	1, Wideband (W)	4, Wideband (W)	1	1	1	1
Measurement	Temperature, °C Strain, $\mu\epsilon$	Temperature, °C Strain, $\mu\epsilon$	Temperature and Strain	Temperature and Strain	Temperature	Temperature
Precision	0.1-1°C or 1-10 $\mu\epsilon$ depending on sample rate	0.1-1°C or 1-10 $\mu\epsilon$ depending on sample rate	Sensor Configurations: A-n-W-GL-FI P-n-W-GL-FI UHS-n-W-GL-FI	Sensor Configurations: A-n-W-GL-PK P-n-W-GL-PK	Sensor Configurations: P-n-W-GL-SI UHT-n-W-GL-SI UHT-n-W-GL-AC	Sensor Configurations: P-n-W-SST-SSC UHT-n-W-SST-SSC
# of FBGs per Sensor (n)	1-30	1-30	1-30	1-30	1-30	1-30
Sample Rate/channel	1-100Hz	1-100Hz	Min FBG spacing=2mm Max length=500m	Min FBG spacing=2mm Max cap length=10m	Min FBG spacing=2mm Max cap length, SI=2m, AC=1m	Min FBG spacing=2mm Max cap length=3m
Operating Temperature	0°C to +60°C	0°C to +60°C	Capillary Section: For A: -40°C to +80°C For P: -40°C to +300°C For UHS: -250°C to +300°C	Capillary Section: For A: -40°C to +80°C For P: -40°C to +300°C	Capillary Section: For P: -40°C to +300°C For UHT: -250°C to +800°C	Capillary Section: For P: -40°C to +300°C For UHT: -250°C to +800°C
Applications	Laboratory or Embedded OEM	Laboratory or Embedded OEM	General purpose. Supports temperature and strain measurements. FBGs must be strain-relieved for temp.	Flexible tubing provides protection of internal FBGs, as required by specific applications.	Provides strain-relieved, semi-rigid temperature probe for measurements to +800°C.	Provides strain-relieved, rigid temperature probe, well-suited for high temp measurements to +800°C.
Electrical Interface	UART and microUSB	UART and microUSB	---	---	---	---
Optical Interface	FC-APC	FC-APC	FC-APC	FC-APC	FC-APC	FC-APC
Power Supply	+5VDC or USB	+5VDC or USB	---	---	---	---
STOCK PRODUCTS	FBGX100	FBGX400	Available for initial engineering evaluation: FBG-MR0050, 1-FBG FBG-MR0010, 10-FBG Or ordered per customer-specified configuration	Ordered per customer-specified configuration	Ordered per customer-specified configuration	Ordered per customer-specified configuration
© 2023, MICRONOR SENSORS INC.			P=Polyimide-Coated Fiber, A=Acrylate-Coated Fiber (rated -40C to +80C) UHS=Ultra High Strength, Pure Silica Core Fiber with No Coating UHT= Ultra High Strength, Pure Silica Core Fiber with Polyimide Coating			98-FISN-06-A
All specifications are subject to change without notice						QR Code to FBGs



MICRONOR SENSORS, INC.
www.micronor.com

2085 SPERRY AVE, STE A-1
VENTURA, CA 93003 USA

+1-805-389-6600
sales@micronor.com
<https://www.micronor.com>



Performance Comparison of Key Thermometry Technologies

Typical Characteristics	K-Type Thermocouple	GaAs	FBGs
Measurement Range	-270°C to 1260°C	-200°C to +300°C	8.65 pm/°C -250°C to +800°C (depends on FBG Sensor Chain configuration)
No. of Measuring Points per Sensor	1	1	1-30, min 2mm spacing
Accuracy	±2.2°C	±0.2°C (1σ)	± 1-2 °C (1σ)
Resolution	0.1°C	0.1°C	0.1°C – 0.5°C
Update Rate	0.1 Hz	1-ch = 4 Hz 4-ch = 1 Hz	1-200 Hz (FBGX100) 1-2000 Hz (FBGX1000)
Max Distance	50m	2000m	500m
Wire Used	Metallic	Multimode Glass Fiber 200/220	Single Mode SM800P 5.6/125
Ease of Integration	Plug-and-play	Plug-and-play	Requires Hardware and Software Integration

Performance Comparison of Key Strain Sensor Technologies

Typical Characteristics	Load Cell	Thin Film Strain Gauge	Optical Strain Guages (LW FBGs)	FBGs (SW FBGs)
# of Points per Sensor	1	1	Single point (1550nm)	1-30, min 2mm spacing (850nm)
Measurement Range	Measure force, 0-10 kN	±500 $\mu\epsilon$	1.4 $\mu\text{m}/\mu\epsilon$ ±2,500 $\mu\epsilon$	0.7 $\mu\text{m}/\mu\epsilon$ ±3,000 $\mu\epsilon$ for 10 FBGs ±2,000 $\mu\epsilon$ for 30 FBGs
Operating Temperature Range	-40°C to +140°C	-40°C to +85°C	-40°C to +85°C	-250°C to +300°C Depends on FBG Sensor Chain Configuration
-3dB Frequency Response or Digital Sample Rate	1-10kHz	1-10kHz	1-100kHz	FBGX100 1-100Hz FBGX1000 1-2000Hz
Output	Analog	Analog	Digital	Digital
Max Distance	<10m	<10m	>>1000m	500m
Wire Used	Metallic (2-4 Wires)	Metallic (2-4 Wires)	Single Mode Fiber SMF28	Single Mode Fiber SM800-5.6/125
Ease of Integration	Plug-and-play	Plug-and-play	Somewhat Plug-and-Play	Requires Hardware and Software Integration

Case Study #1: Medical – RF Radiotherapy



Patient Monitoring during hyperthermia cancer treatment

CHALLENGE

Monitor patient skin temperature during High-RF Field hyperthermia cancer treatment. Requires immunity to RF fields. Measurement range is 0-80°C (23°F to 176°F).

SOLUTION

TS5 temperature probe is taped to patient's skin during hyperthermia (RF heating) cancer treatment



Case Study #2: Medical – RF Ablation

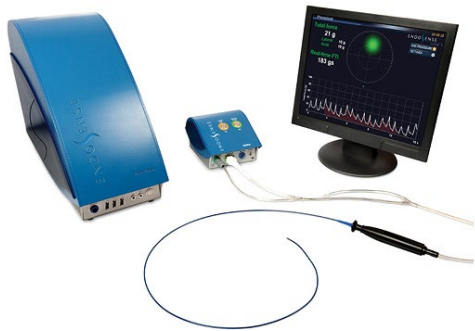
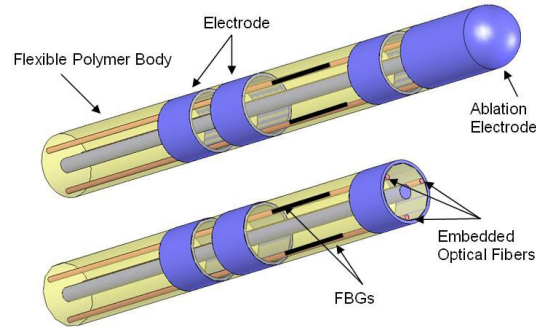
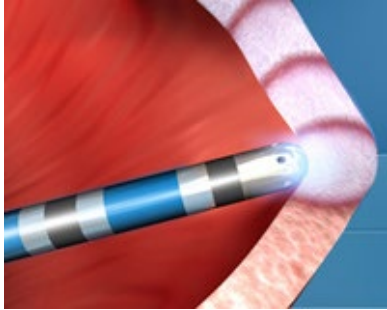

CHALLENGE

RF ablation catheter is directed through the body and positioned to burn off tumors. Physicians require real-time, objective measure of contact force during treatment of cardiac arrhythmias or tumors.

SOLUTION

The TactiCath force-sensing ablation catheter provides physicians with a real-time, objective measure of contact force during the treatment of cardiac arrhythmias. It includes a smaller fiber optic sensor at the tip, a force-time integral display and automatically generated summary reports of the procedure. Contact force is derived from three sensor fibers which measure micro deformation of the catheter tip using Fiber Bragg Grating technology.

Case Study #3: Medical – MRI Guided Robotics



CHALLENGE

Monitor patient skin temperature, ambient temperature, as well as operate robotic equipment and other medical devices that need to operate within the MRI bore. Magnetic field strength up to 9 Tesla (T).

SOLUTION

Fiber optic temperature sensors, position sensors, and microswitches are immune to magnetic fields and other interference.

MRI Guided Biopsy Robot

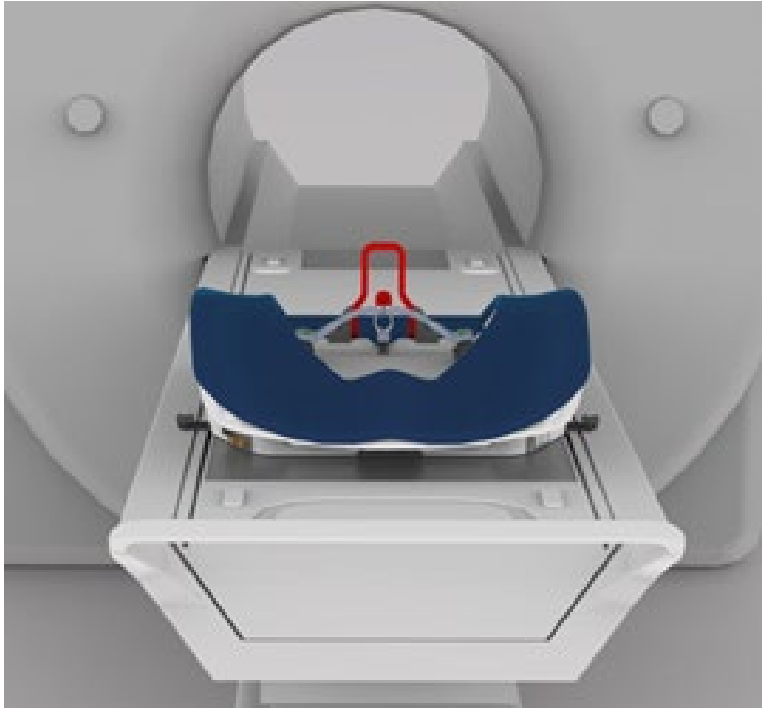

Photos and renderings courtesy of
Polymer Robotics / Umamo Medical

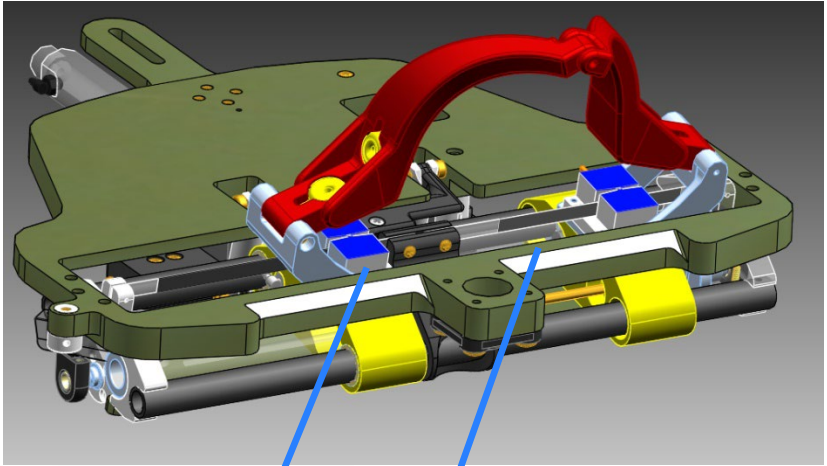

Precision MR343
Incremental
Film Strip
(2 Axes Shown)

MRI Dynamic Brain Phantom

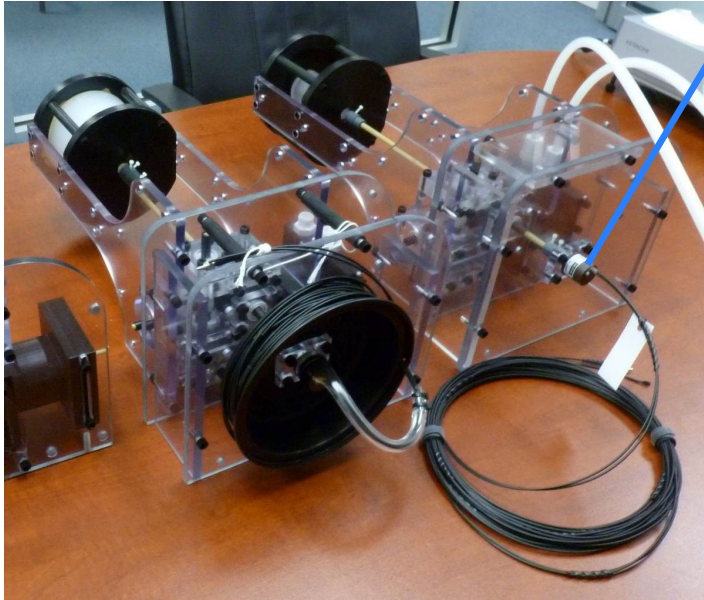

MR431 POF-based
Absolute Encoder



The ALA SCIENTIFIC MRI Dynamic Brain Phantom is designed to address training and quality assurance protocols for MRI machines by providing rapid control feedback from within the MRI bore, while remaining invisible to MRI scans.

New FBG-based Optical Sensors enable new medical and industrial robotic applications.

GR25 Optical Gripper Finger Sensor

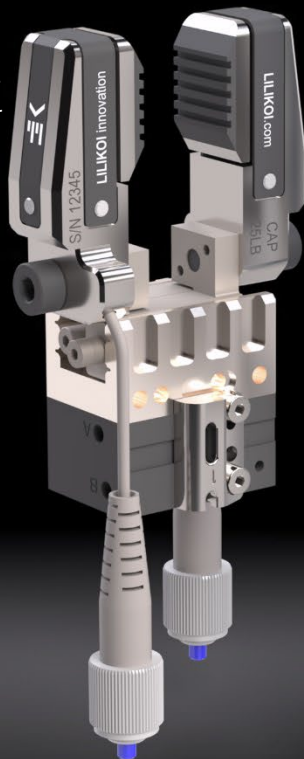

FG25 Femto In-line Force Sensor



GS05 Optical Grasper

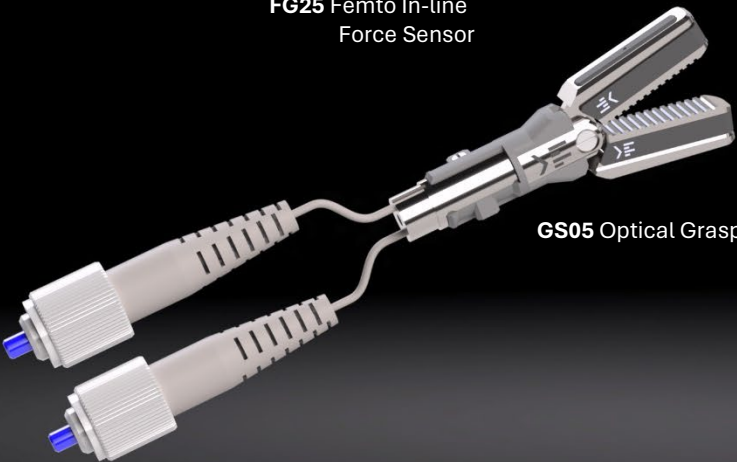

SB20 & SB30 Smart Bracket Force Sensors



LILIKOI
innovation

micronor
sensors



FG25 FEMTO MINIATURE INLINE FORCE SENSOR

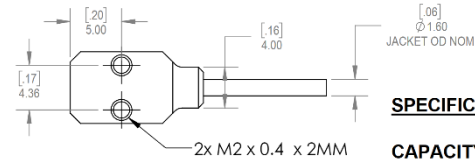
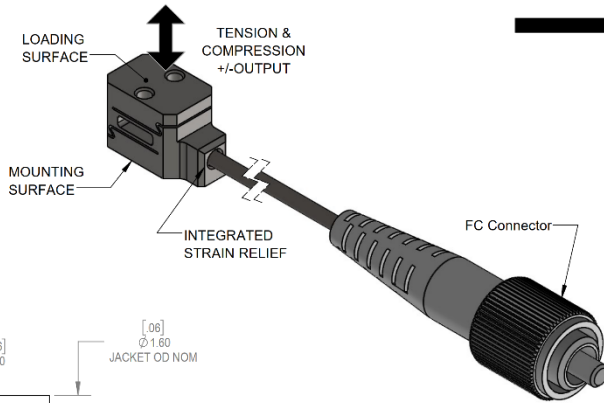

SPECIFICATION:

CAPACITY: 25 LB
OUTPUT ($\mu\epsilon$): 3500 at FS nom.
FORCE FBG WL [nm]: 838 (T) & 878 (C)
FIBER OP WL [nm]: 830
NON-LINEARITY: 0.5% R.O.
OPERATING TEMP: -55°C[-67°F] to 200°C[392°F]
TEMP SHIFT ZERO: +/- 0.005% R.O./°C
TEMP SHIFT SPAN: +/- 0.002% R.O./°C
SENSOR BODY: STAINLESS STEEL
CABLE LENGTH: 1m [3.3ft]
CABLE JACKET: 1.6mm GLASS TEXTILE
CONNECTOR: OPTICAL FC

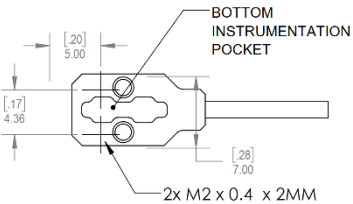
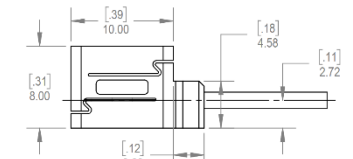

Patent Pending

- **Tension and compression** force measurement for harsh environments:
 - High temperature (200degC), moisture and EMI immunity
 - 25lb capacity, temp compensated with 0.5% nonlinearity
 - Redundant M2 mounting provisions.
 - Aerospace, semi-conductor, medical application.
- **Dual sensing FBG output:**
 - Real time compensation of thermal and off-center loading effects
 - Compatible with 800nm FiSens interrogators

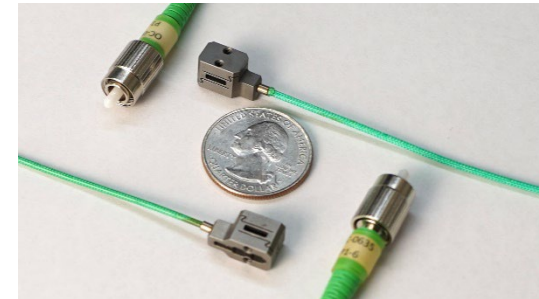
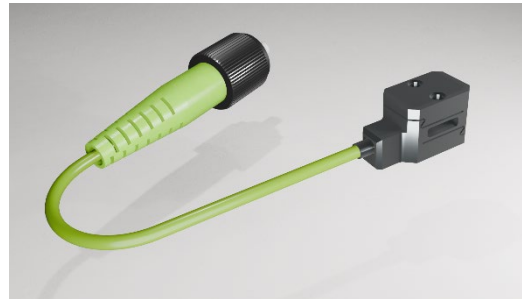



SMART BRACKET SENSOR - FULL BRIDGE STRAIN GAGE LOAD CELLS

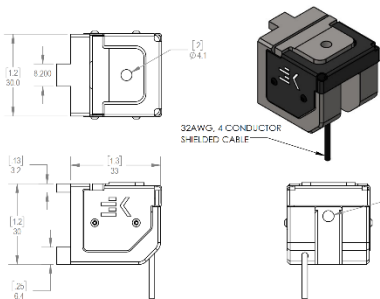

SB30 SMART BRACKET

PATENT PENDING

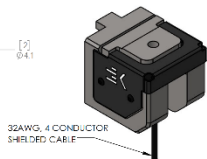

32AWG, 4 CONDUCTOR SHIELDED CABLE

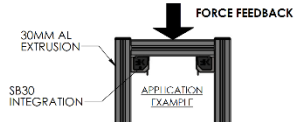
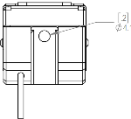

SPECIFICATION:

CAPACITY: 10-200LB
 RATED OUTPUT: 2mV/V
 NON-LINEARITY: 0.05% R.O.
 BRIDGE RESISTANCE: 350 Ohm
 OPERATING TEMP: -50-150°C [-60-160°F]
 TEMP SHIFT ZERO: 0.01% R.O./degC

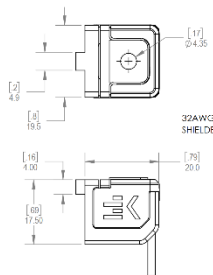

SB20 SMART BRACKET

PATENT PENDING

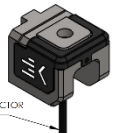

32AWG, 4 CONDUCTOR SHIELDED CABLE

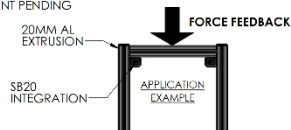
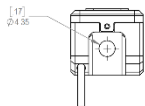

SPECIFICATION:

CAPACITY: 5-100LB
 RATED OUTPUT: 2mV/V
 NON-LINEARITY: 0.05% R.O.
 BRIDGE RESISTANCE: 350 Ohm
 OPERATING TEMP: -50-150°C [-60-160°F]
 TEMP SHIFT ZERO: 0.01% R.O./degC



Patent Pending



Case Study #4: Biomedical Research-Nanoparticles



CHALLENGE

Magnetic nanoparticles are heated with induction to selectively ablate tumor cells, powers from 1kW to 10kW, frequencies from 150kHz to 400 kHz. This non-contact selective heating only elevates the temperature of the material or tissue with embedded magnetic nanoparticles. Requires RF immune temperature sensor to monitor actual temperature.

SOLUTION

Ambrell EASYHEAT® System is a compact induction heating system for the lab which offers Weidmann TS3 GaAs sensor (both non-metallic and RF-immune) for both temperature indication and closed loop control of the customer's process.



Case Study #5: Food Processing - Microwaves



Commercial Microwave Oven and Industrial Microwave Conveyor Drying Machine

CHALLENGE

Measuring temperature of food and similar samples while being heated in Microwave Oven. Food can absorb microwaves, but metal can only reflect. This can cause a dangerous arcing condition between the metal object (conventional temperature probe) and the metal walls of the microwave oven. Monitor temperatures to 200°C.

SOLUTION

Fiber optic temperature sensors are both non-metallic and immune to microwaves.

Compared with traditional natural defrost thawing, flooding or water thawing, microwave defrosting has advantages of short time, uniform internal/external heating, kills bacteria, and no loss of nutritional components.



Gefilte Fish: Using Microwave Ovens

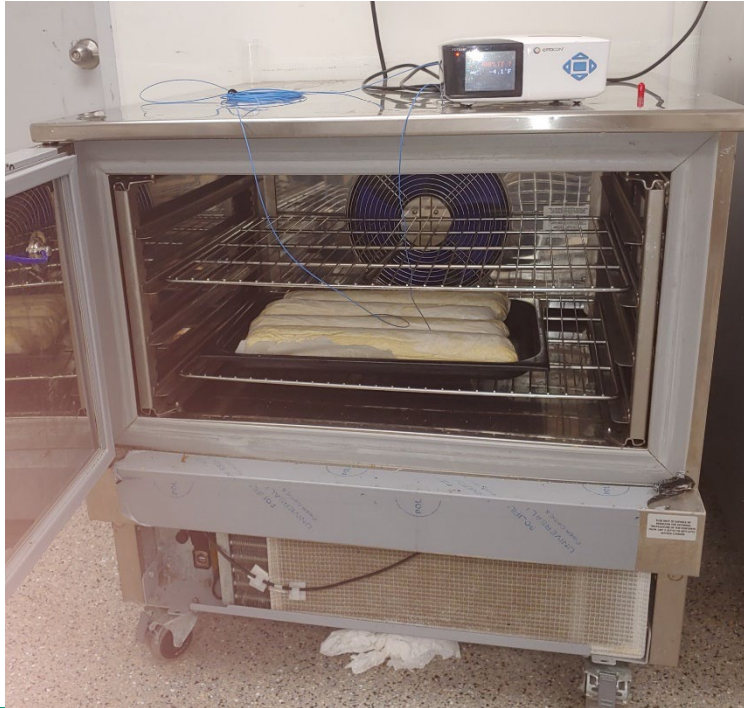
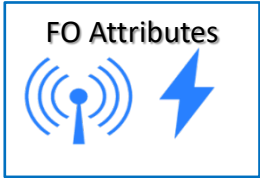

CHALLENGE

Develop optimized process for meat thawing as well as production of partially cooked food product.

SOLUTION

A&B Famous Gefilte Fish uses multichannel Bench Top FOTEMP signal conditioner together with TS3 series GaAs temperature probes.

A&B developed a proprietary microwave oven-based process for raw fish thawing as well as production of their partially cooked frozen gefilte fish product. For the latter, a microwave oven process was developed that precisely cooks and cools the product without rendering the proteins fully cooked.

Microwave Food Processing using TS3 GaAs Temperature Probe



Case Study #6: Electric Train Pantograph

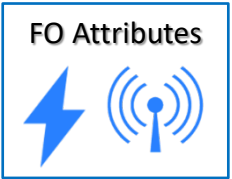

CHALLENGE

Dynamically monitor pantograph operation in real time during train operation. A serious failure of pantograph can not only damage contact wires but can also inflict widespread damage on the catenary system network.

SOLUTION

Providing high voltage immunity and isolation, a multi-axis fiber optic accelerometer mounts directly on the pantograph to monitor system health in real time. Customer: Swiss Railway

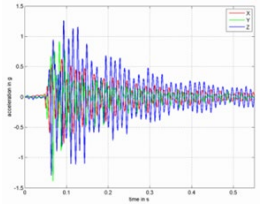

25kV Fiber Optic Insulator/Isolator For Pantograph Sensor Feedthrough

P/N 9800.03.000

DATE OF TEST: from 2009-08-13 till 2009-08-27	TEST No.: 9522/09
TEST REPORT No.: 9522/09	
TEST OBJECT:	Composite insulator contains a fibre-optic cable
TYPE SPECIFICATION:	9800.03.000
MANUFACTURER:	PFISTERER SEFAG AG, MICRONOR AG, SWITZERLAND
TEST STANDARD:	IEC 61952:2008, IEC 62217:2005, IEC 60383-1:1993, IEC 60060-1:1989
TEST PERFORMED BY: Oldřich Jeřek 	MANAGER OF QUALITY: Marek Brosch 
COPIES: 3+1	PAGES: 16



ACCREDITED TESTING LABORATORY
EGU - HV Laboratory s.r.o.
PRAGUE
No. 1029



Case Study #7: Power Generators, Heavy Machinery

FO Attributes

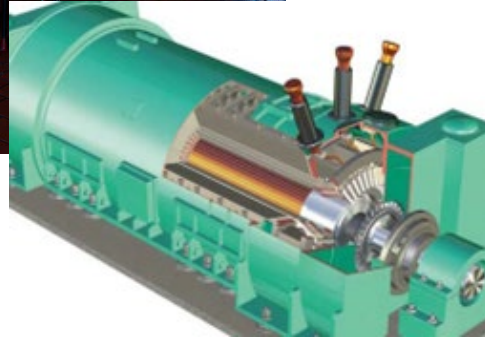
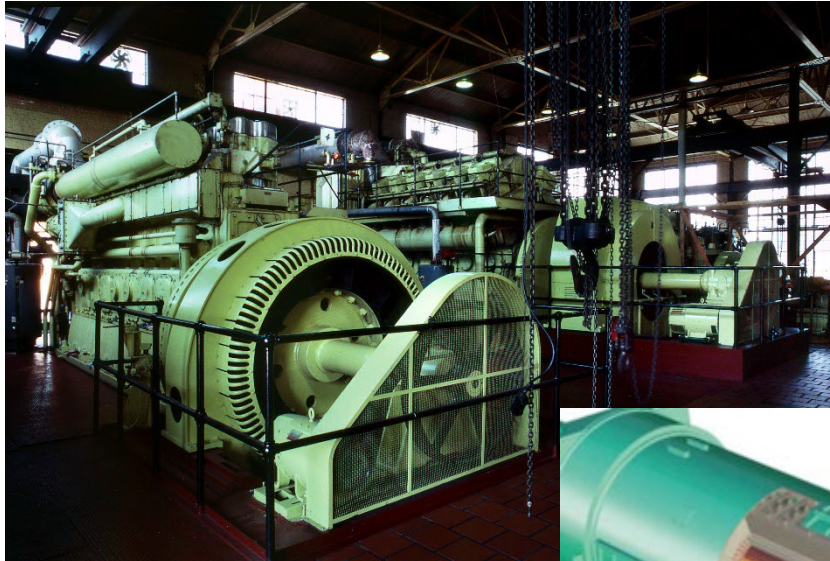

CHALLENGE

Monitor health of rotary generation equipment and large motors. Buildup of vibration can be a direct indicator of deteriorating bearings and other mechanical degradation. Internal potentials range from 15 kV to 10,000 kVA.

SOLUTION

Providing high voltage immunity and isolation, a multi-axis fiber optic accelerometer mounts directly on generator housing to monitor dynamic vibration in real time.



Case Study #8.1: Energy -Health Monitoring of Transformer Hotspots & Bus Bars

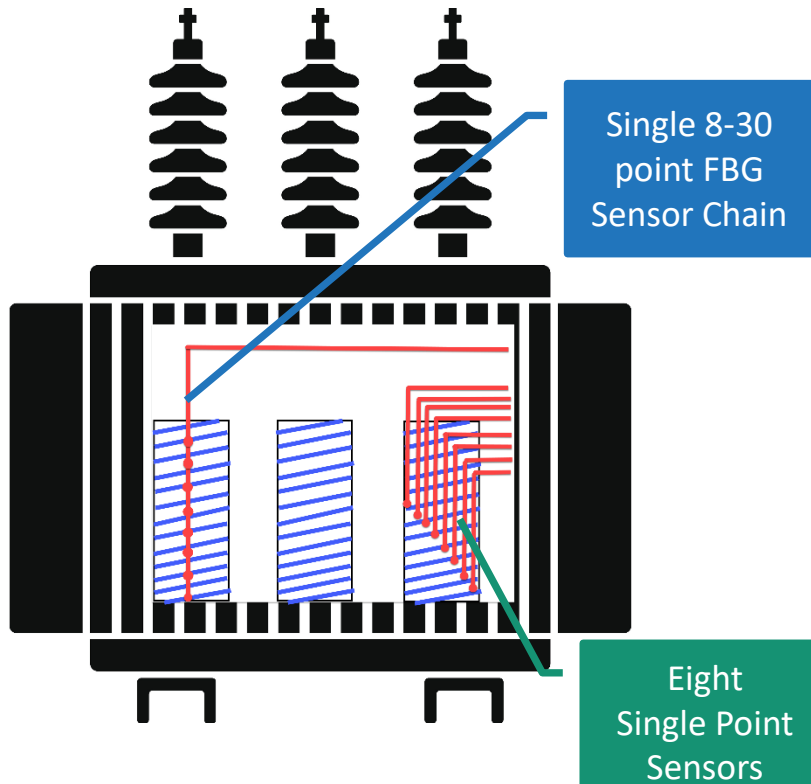

CHALLENGE

Safe monitoring of generation and distribution transformers with internal potentials range from 15 kV to 10,000 kVA.

SOLUTION

Fiber optic temperature sensors provide inherent immunity to high voltages.

Real-time Hotspot Temperature Sensing monitors health of the transformer, improves reliability, and prevents unscheduled system failures and outages.

Current system uses 24x TS2 GaAs Temperature Probes. Future system simplifies system using only 3x FBG probes providing greater fidelity = up to 90 monitoring points.

Case Study #8.2: Transformer Vibration Monitoring

FO Attributes



CHALLENGE

Monitoring stator endwinding vibration for health monitoring of utility transformers and reactors. Buildup of vibration can be a direct indicator of deteriorating transformer health which trigger preventive maintenance or replacement before catastrophic failure. Internal potentials range from 15 kV to 10,000 kVA.

SOLUTION

Providing high voltage immunity and isolation, a multi-axis fiber optic accelerometer mounts directly on internal transformer windings to monitor dynamic vibration in real time.

Case Study #9: Semiconductor Equipment Mfg

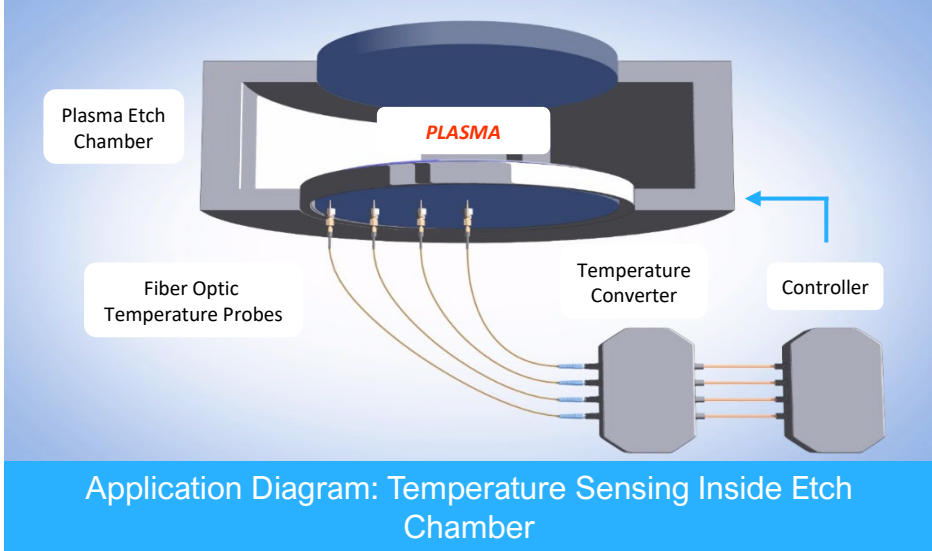
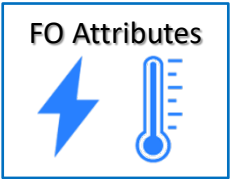

CHALLENGE

Precisely measuring temperature in Plasma Etch Vacuum Chamber during wafer etching. Monitoring and controlling temperature improves wafer yields and lowers costs. Requires immunity to RF and plasma fields.

CURRENT SOLUTION

Current processes use single point fiber optic temperature probes, based on GaAs, Phosphorescence or Fluorescence. Working temperatures to 450°C and absolute accuracies down to $\pm 0.2^\circ\text{C}$.

GaAs is the only technology that is absolute, based on intrinsic properties of GaAs. Phosphorescent and Fluorescent probes are based on well-characterized phosphor compounds which require calibration/based



EMERGING SOLUTION

Multipoint FBGs Promise More Comprehensive Temperature Feedback in Semi Device Manufacturing Processes

FBG Demo on Plasma Shower Head

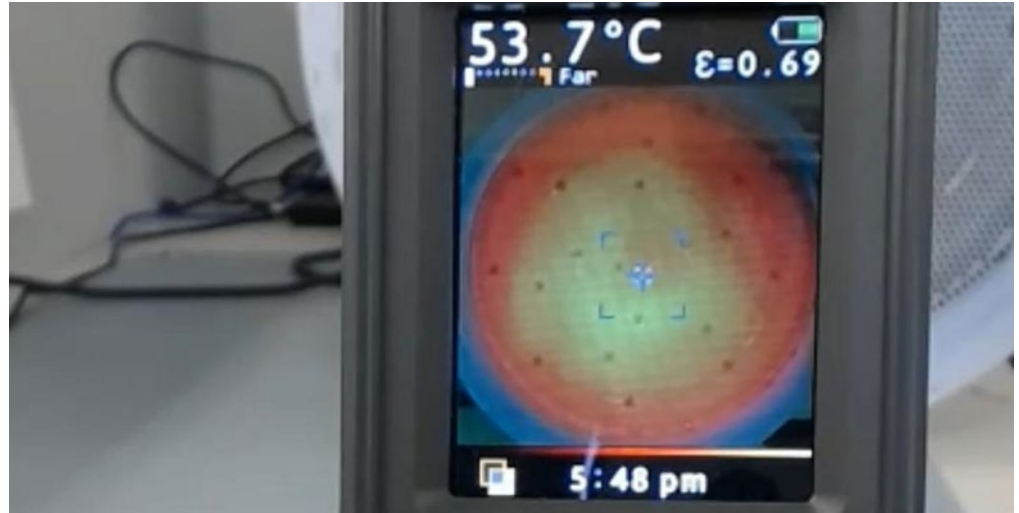
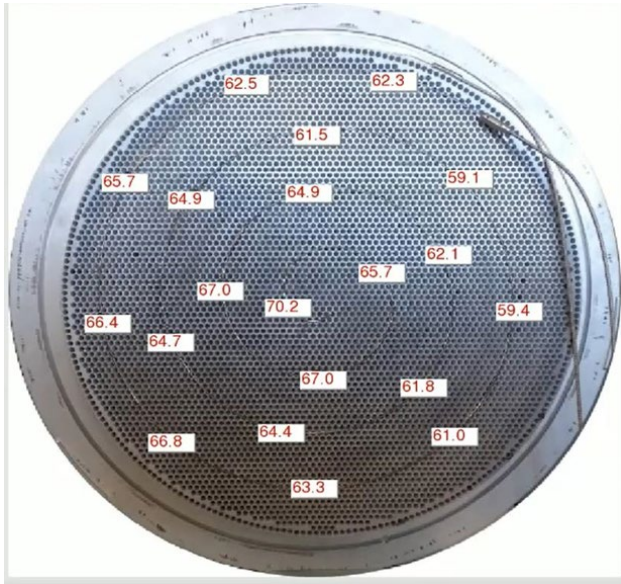



Case Study #10: Structural and Health Monitoring for Reliability & Safety



Civil Structure Health and Safety Monitoring



Infrastructure Health and Safety Monitoring

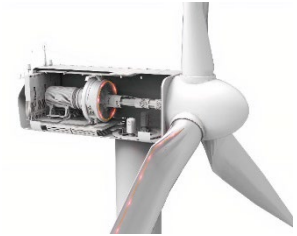

Wind Turbine Blade and Generator Health Monitoring



Aircraft Structural Health Monitoring

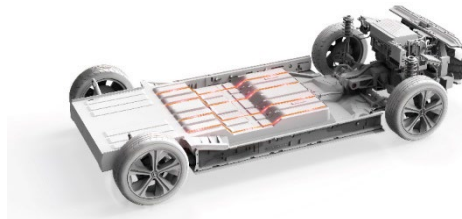

Battery Health Monitoring



Load and Balance Safety Monitoring

Basic Fiber Do's and Don'ts

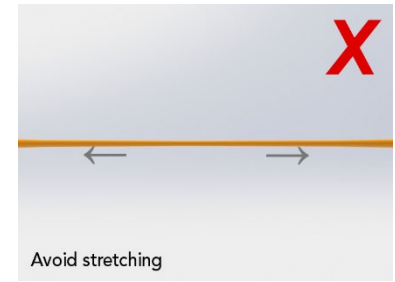
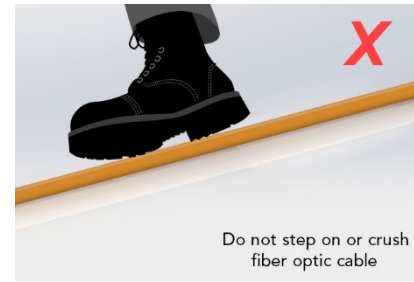
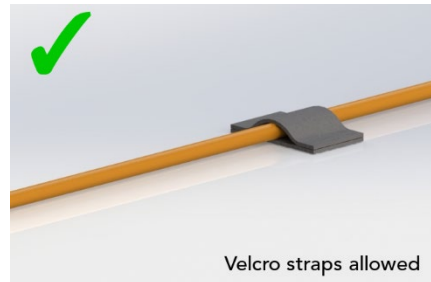
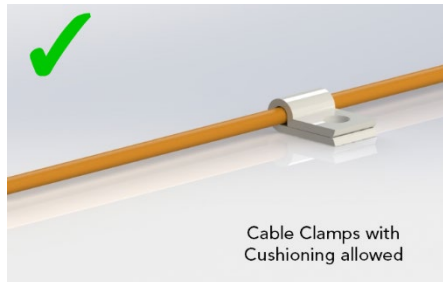
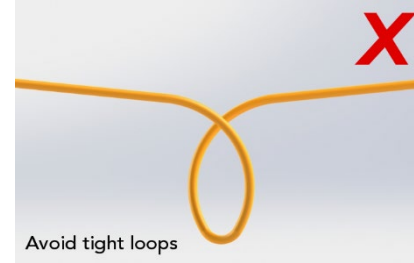
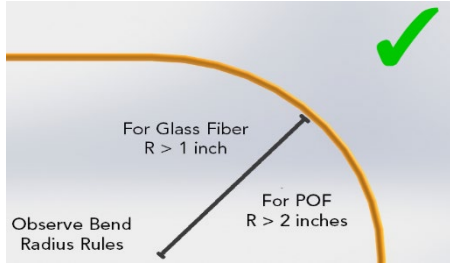

Summary

- ❑ MYTH: Fiber optic sensors are not fragile, glass things. FO is very robust and reliable.
- ❑ Fiber optic temperature sensors solve many environmental and packaging challenges in the unique operating conditions of many medical and industrial applications – beyond the capabilities of conventional electronics-based sensors, i.e. where immunity to interference, e-fields, magnetic fields, rf fields, or long distances is required.
- ❑ Fiber optic temperature sensors enhance applications where thermocouples are incompatible and offer real-time monitoring solution improving the operation and reliability of the overall system, i.e. RF Ablation, MRI, Transformer Hot Spot Monitoring, etc.
- ❑ Fiber Bragg Grating sensors offer both temperature and strain monitoring in a single fiber sensor for the most compact sensor solution. Multipoint sensor chains provide high fidelity not possible with other sensor technologies.
- ❑ Reach out for a fiber optic temperature sensor solution in your next project.

Micronor Sensors

Fiber Optic and Electromechanical Sensors

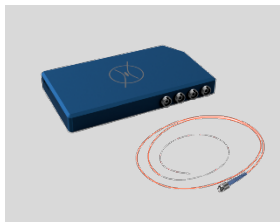

Fiber Optics

- Absolute and Incremental Encoders
- Emergency Stop
- Microswitch
- Accelerometer
- Precision Temperature (Optocon FOTEMP)
- Temperature and Strain (FiSens FBGs)
- Force and Strain (Lilikoi Innovation)

Electromechanical

- Position Transducers/Feedback Units
- Rotary Limit Switches
- Optical/Magnetic Encoders
- Resolvers
- Cam Timers/Motorized Potentiometers
- HMI – Handheld Pendants and MPGs
- Force and Strain (Lilikoi Innovation)

MICRONOR[®]
optical sensors

OPTOCON[®]
OPTICAL SENSORS AND SYSTEMS
by WEIDMANN

FiSens

LILIKOI Innovation

MICRONOR[®]
mechanical products

Questions?



Dennis Horwitz

President
Micronor Sensors

Direct +1-805-242-4296
dennis@micronor.com

micronor sensors

Micronor Sensors, Inc.
2085 Sperry Ave, Suite A-1
Ventura, CA 93003
USA

Main +1-805-389-6600
Sales sales@micronor.com